

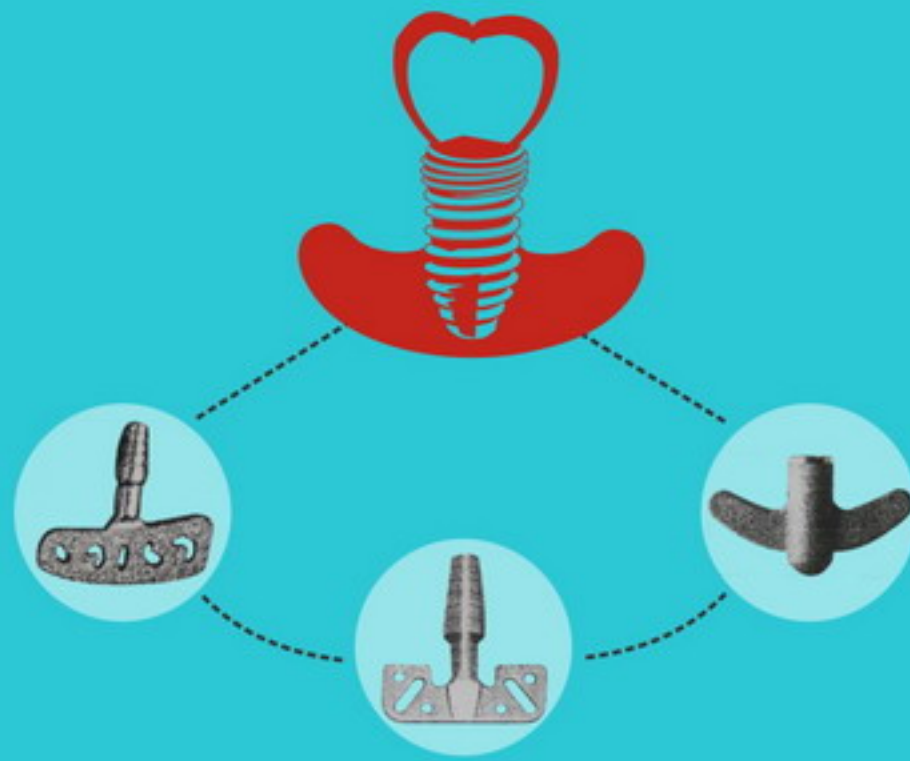

BONE LEVEL  
**SB-II**

Anker Dental Implant System

*Designed to Smile*



## Anker Dental Implant System

For centuries, clinicians have attempted to replicate teeth through implantation.

By the end of the 1970's groundbreaking studies, led by Dr. Per-Ingvar Branemark, had emerged.

They concluded that pure titanium integrates with bone tissue without complication.

Intraorally, an abutment can be connected to an implant

and used as a tooth replacement with predictable clinical outcomes.

Early publications refer to the dental implant as an “anchor,” or “anker” in German

and Danish. In honor of the innovation, evolution and heritage of implants,

Alliance Global Technology proudly presents the Anker Implant System.





# CONTENT

Company Introduction 01

Surface Treatment 02

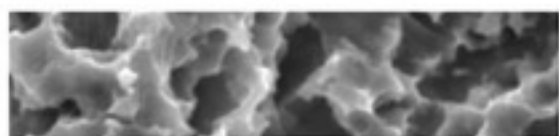

Features 03



- Platform Switching
- S.L.A Surface Treatment
- Root-form Design
- Internal Hexagon 11° Morse Taper
- Double/ Micro Thread

Implant Package 04

Color Coding  05

Flowchart 06

Drilling Sequences 07~08

Product Specification 09~23

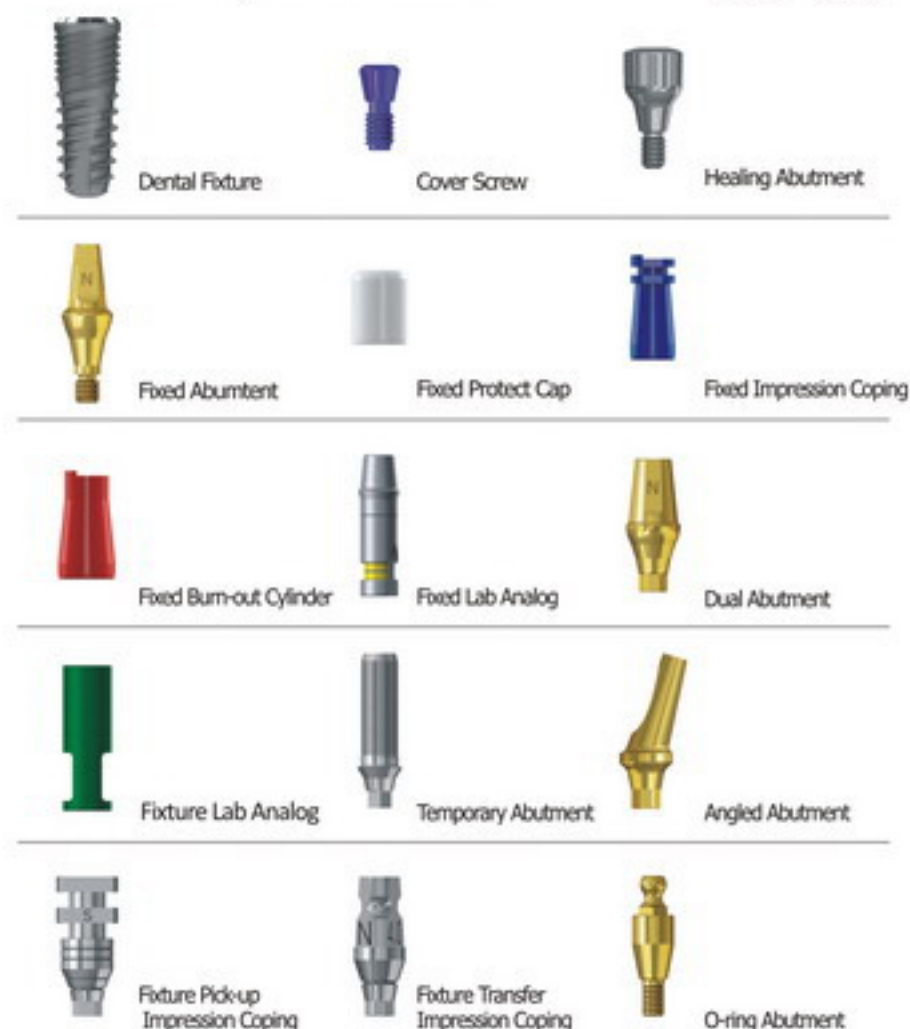

Surgical Kit 24~36



International Activities 37

Milestone 38

Certificates 39



## Surgical Instruments Care and Maintenance

### Caution! The drills need to be sterilized before use

1. Do not use cleaning solution or disinfectant containing chloride or acid (caution with the running water too much chlorinated)
2. Avoid solution with aldehyde, owing to the ability of this product to keep the proteins
3. Eliminate meticulously all the post-operative residues on the drills, or inside for the drills with internal irrigation
4. Use a nylon brush to avoid, as much as possible, shocks and contacts with other drills or instruments
5. Do not clean, in the same ultrasonic box, the implant drills with other tools which material is different
6. Use suitable cleaning solutions. Respect the manufacturer directions for use
7. Rinse, and then dry the drills immediately after the cleaning process. It is necessary to be meticulous during the drying
8. Stock the drills in clean and dry areas
9. Sterilization by wet heat autoclaving 134°C (273° F) 40 minutes. Make sure that the elements, inside the autoclave, are not rusted
10. For the drills with removable stops: these steps must be carried out individually on the dismantled component

## Lifetime Warranty

In the case of failure of implantation, Alliance would offer the replacement by submitting the fully documentation including the failure form, before and post surgery radiograph taken, and the failed implant within 6 months from the beginning of the event.



# COMPANY INTRODUCTION



Alliance Global Technology Company established in 2008, has grown to become a worldwide dental implant and dentistry provider.

We collaborate between government, industry, and academics including senior scientists from prestigious research institutes. Our parent company, Anchor Group, focus on fasteners producing especially for aerospace and motor industry for over three decades.

It's our strong advantages that Alliance acquired parent company's precision technical ability and consistent dedicating on implant dentistry innovation.

The chairman of Anchor Group and of Alliance, Tompson Chang, is committed to the level of distinction in the design and fabrication of quality components for the dental implant world. Our mission is to improve the health and well-being of those in need.



Alliance has launched numerous live surgery dental implant training programs in conjunction with universities and dentist. Aimed at dentist intent to learn and improve the skills in dental implantology.

Alliance Global Technology is located in Kaohsiung, Taiwan. , Thus far, Alliance always care about the long-term relationship with dentists in worldwide, concerns how to meet more and more patients requirement.

Anchor group the new headquarter, with area of 1.5 hectare construction project estimate finish in the near future.





# SURFACE TREATMENT

Anker Dental Implant Surface Treatment : S.L.A / SLA-CaP

1. Following the unique sandblasting, large grit , acid-etched is tended to increase the roughness of the surface and amplify BIC (Bone-Implant Contact). Surface roughness evolves a better consequence after treatment accordingly to SEM **Figure 1** is even better than those leading peers. The surface roughness increased 39% after S.L.A treatment, further eases the attachment of Osteocyte, and boost Osseointegration.
2. Fixtures are sent to multi-step ultrasonic cleaning with high purity water (Reverse Osmosis). Once the surface is completely cleaned with no residues, it could be ready to pack in the Class 1000 clean room. The packed implant will be sent to  $\gamma$  - rays sterilization, and further cell biocompatibility test in the microbiology lab to verify the sterilization authentication. Alliance Implants are ready to launch into the market along all the rigorous quality in-house control.
3. There are no residues shown on the surface of Anker Implant under SEM (Scanning Electron Microscopy). This also demonstrates Anker Implant is reliable with high biocompatible capacity.

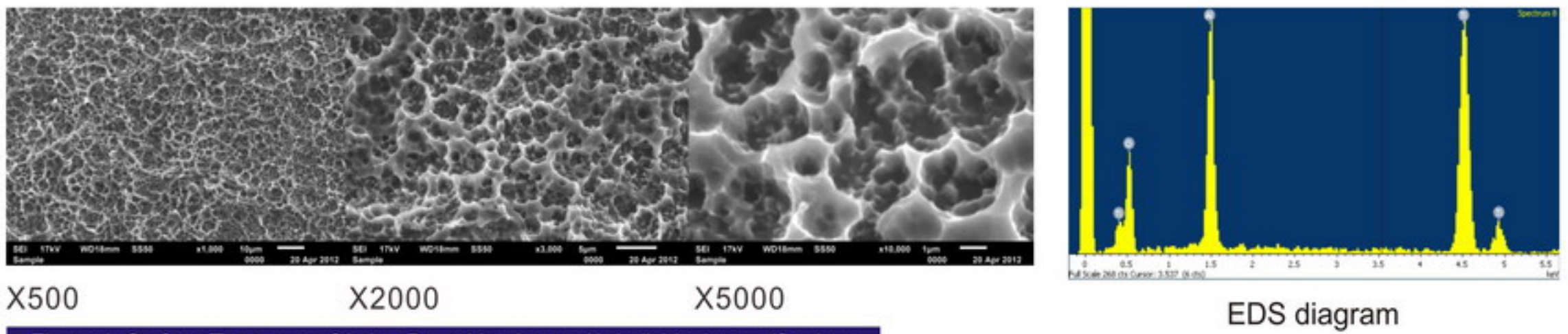
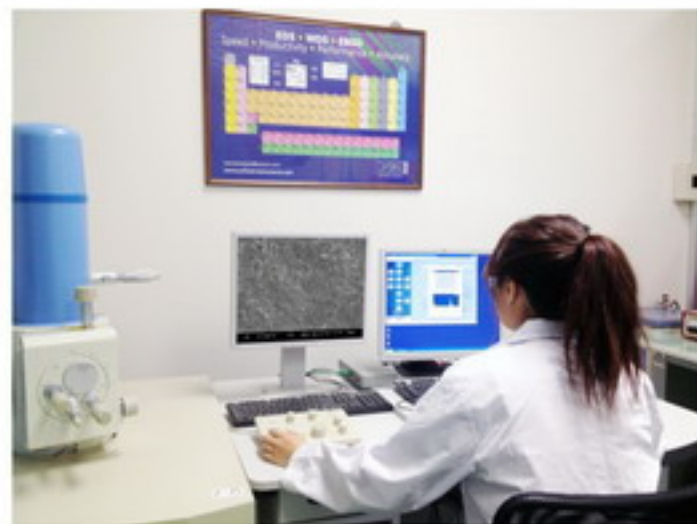

Figure 1. Surface Treatment of Anker Dental Implants with individual magnifications



SEM-EDS(Jeol Japan) ( $3 \times 10^5$  times)



Ultrasonic Cleaning



Exterior Viewing



Sandblasting

Cell Attachment Study

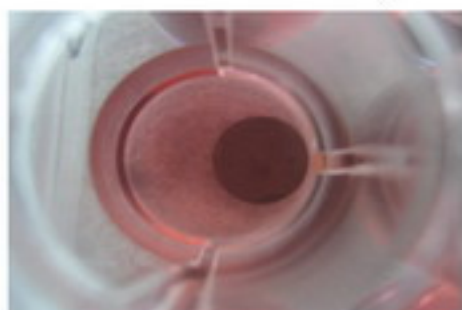

Hydrophilicity Testing

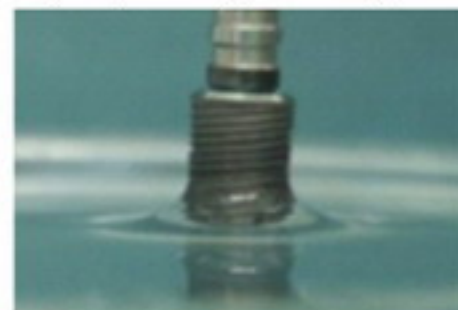

Ultrasonic Cleaning  
(Class 1000 Clean Room)



# FEATURES

The principle goal of implant design is to enhance osseointegration, shorten treatment time, and improve reliability and esthetics.

To that aim, the Anker implant has:

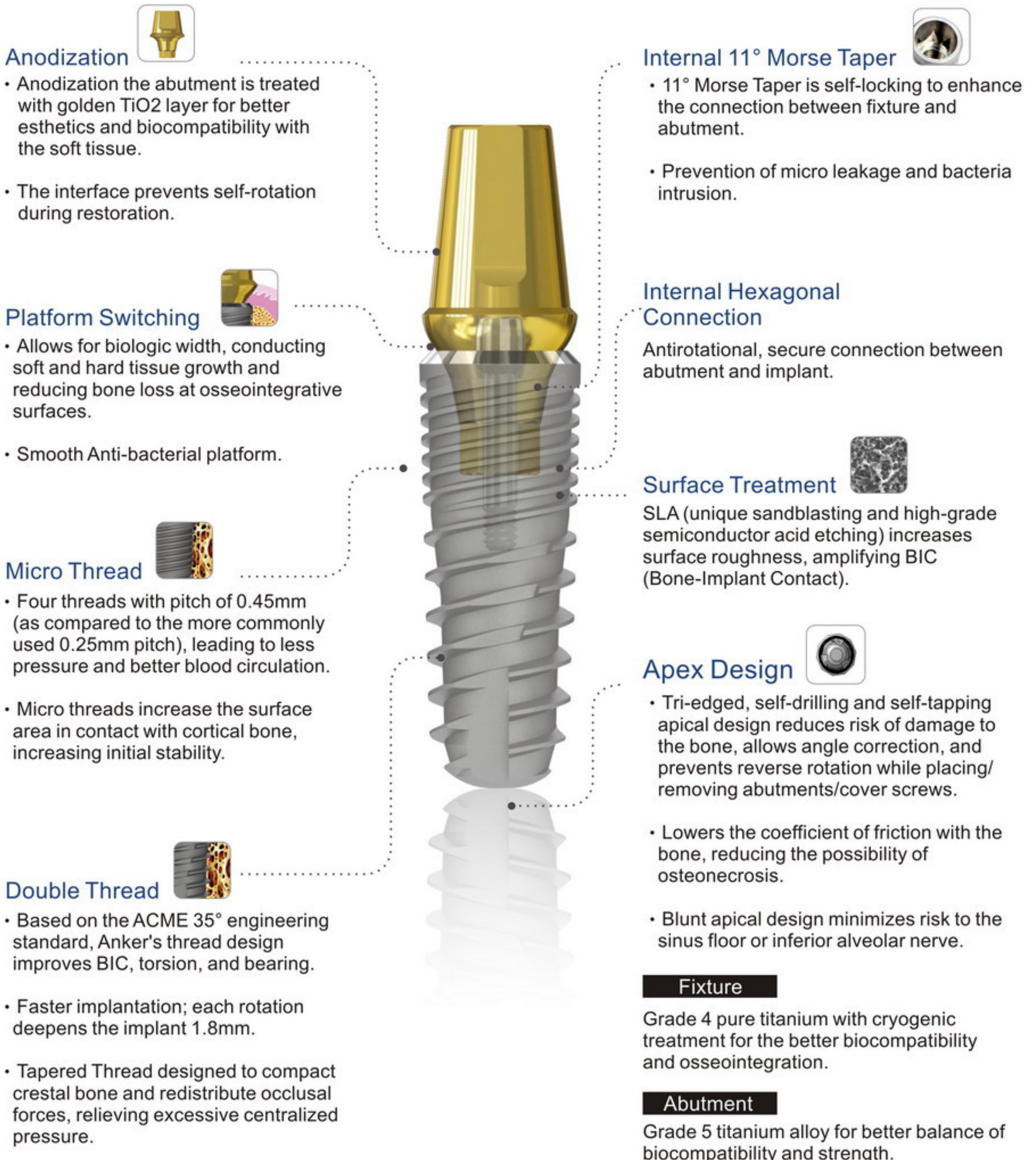



# IMPLANT PACKAGE



1. Reference number
2. Dimensions of Implant
3. Batch code
4. Date of sterilization
5. Expiration date
6. Caution
7. Liaison
8. EC REP
9. Sterilization using irradiation sticker

The package includes a user instruction manual and 4 information stickers for documentation



# IMPLANT REMOVAL



To remove the implant with  
**No Mount Piece Driver**



Outer Cap:  
To remove the cover screw  
with 1.2 Hand Driver

Fixture is secured stably with pure titanium cylinder to prevent intrinsic contact potential difference (prevents corrosion)



# COLOR CODING



A specific color is assigned to each diameter of the Anker System

Final Drill Size	
Ø2.4	→ For Ø3.0 Fixture
Ø2.8	→ For Ø3.5 Fixture
Ø3.3	→ For Ø4.0 Fixture
Ø3.8	→ For Ø4.5 Fixture
Ø4.3	→ For Ø5.0 Fixture

Stopper	
Yellow	→ For Both Ø2.8 / Ø3.3 Drills
Red	→ For Both Ø3.8 / Ø4.3 Drills

Clear and simple color coding for user guidance

## Mini Kit

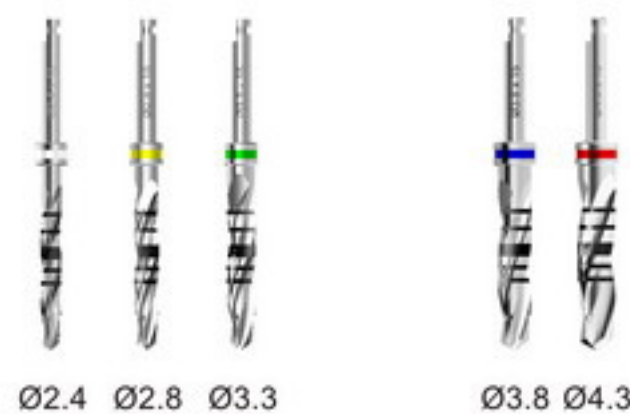

## Taper Kit



# IMPLANTATION CAUTIONS

1. Drill to the appropriate depth using high speed between 800~1200 rpm.
2. In case of strong resistance while inserting the implant into the osteotomy at any point, reverse the implant counter-clockwise approximately 2-3 turns to enable the self-tapping capacity of the implant, then continue to insert the implant.
3. Exceeding the maximum insertion torque of 25Ncm using the No Mount Piece Driver should be avoided. Doing so can cause deformation of the implant or connection and may result in overt compression of the bone.
4. In dense bone (D1 or D2), one may need to widen the implant site with the next diameter to half of the final depth, according to the drill protocol.
5. In case of D4 Bone, it may be better to drill only halfway with the final diameter drill or not use the final diameter drill at all, to achieve sufficient primary stability.
6. The system is designed to be mount-free. Pick up the implant from the vial by using the No Mount Piece Driver. If there is any hindrance during picking up, please inspect whether the O-ring is broken or deteriorated. If so, please immediately report to us, and we will have a replacement for you subsequently.
7. Please rotate the cover screw counter-clockwise before tightening clockwise into the fixture by using the Hex Driver to be sure it engages correctly.
8. The system is separated into Narrow (Ø3.0, Ø3.5) and Standard (Ø4.0, Ø4.5, Ø5.0) type connections. No Mount Piece Drivers and Fixture Drivers have a Yellow stripe for Narrow Connections or a Green stripe for Standard Connections. Please confirm the correct colored Driver is utilized when placing the implant.



# SB-II SERIES FLOWCHART

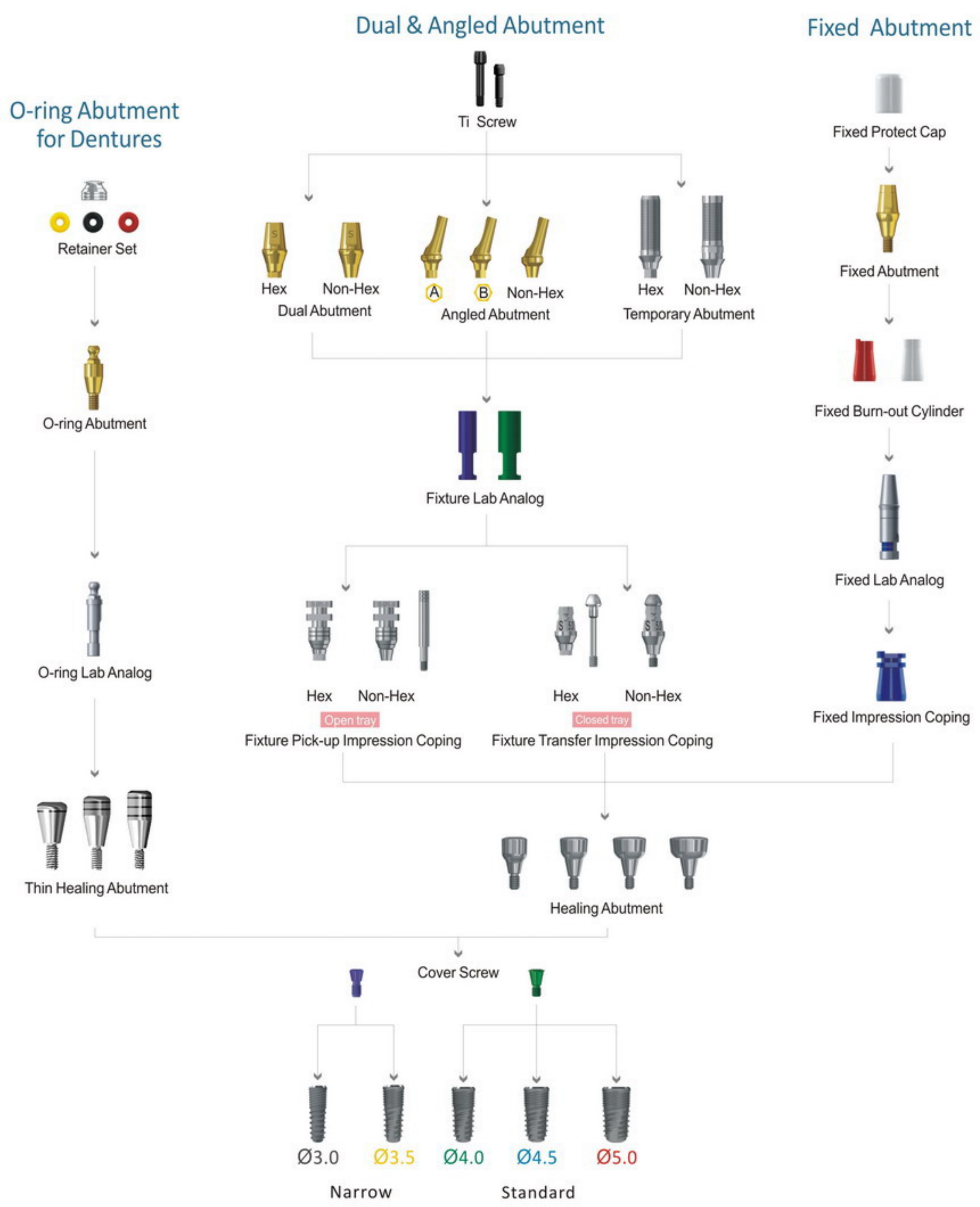



# SB-II MINI KIT DRILLING SEQUENCE

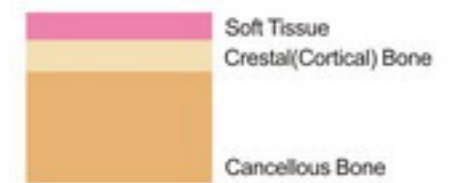

## Fixture 3.0x10mm

- D4 Bone** Lance Drill → Ø2.0mm Twister Drill → Ø2.4 Twister Drill → 2.8 Twister Drill (Drilling to half depth)
- D3/D2 Bone** Lance Drill → Ø2.0mm Twister Drill → Ø2.4 Twister Drill → 2.8 Twister Drill → F3.0 Taper Cortical Drill (Under the black laser line)
- D1 Bone** Lance Drill → Ø2.0mm Twister Drill → Ø2.4 Twister Drill → 2.8 Twister Drill → F3.0 Taper Cortical Drill (Up to stopper)

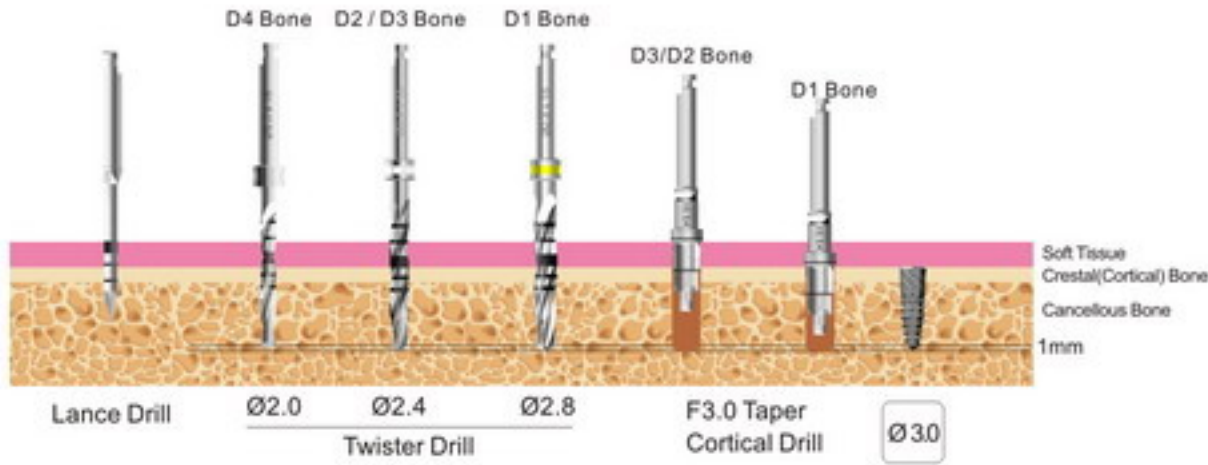

## Fixture 3.5x10mm

- D4 Bone** Lance Drill → Ø2.0mm Twister Drill → Ø2.4 Twister Drill → 2.8 Twister Drill (Drilling to half depth)
- D3/D2 Bone** Lance Drill → Ø2.0mm Twister Drill → Ø2.4 Twister Drill → 2.8 Twister Drill → F3.5 Taper Cortical Drill (Under the black laser line)
- D1 Bone** Lance Drill → Ø2.0mm Twister Drill → Ø2.4 Twister Drill → 2.8 Twister Drill → F3.5 Taper Cortical Drill (Up to stopper)

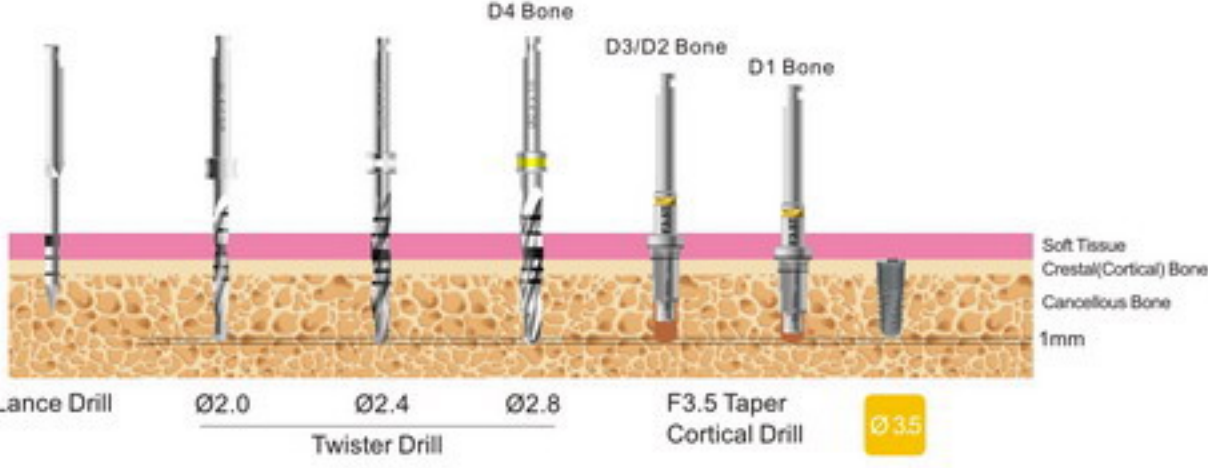

## Fixture 4.0x10mm

- D4 Bone** Lance Drill → Ø2.0mm Twister Drill → Ø2.4 Twister Drill → 2.8 Twister Drill → Ø3.3 Twister Drill (Drilling to half depth)
- D3/D2 Bone** Lance Drill → Ø2.0mm Twister Drill → Ø2.4 Twister Drill → 2.8 Twister Drill → Ø3.3 Twister Drill → F4.0 Taper Cortical Drill (Under the black laser line)
- D1 Bone** Lance Drill → Ø2.0mm Twister Drill → Ø2.4 Twister Drill → 2.8 Twister Drill → Ø3.3 Twister Drill → F4.0 Taper Cortical Drill (Up to stopper)

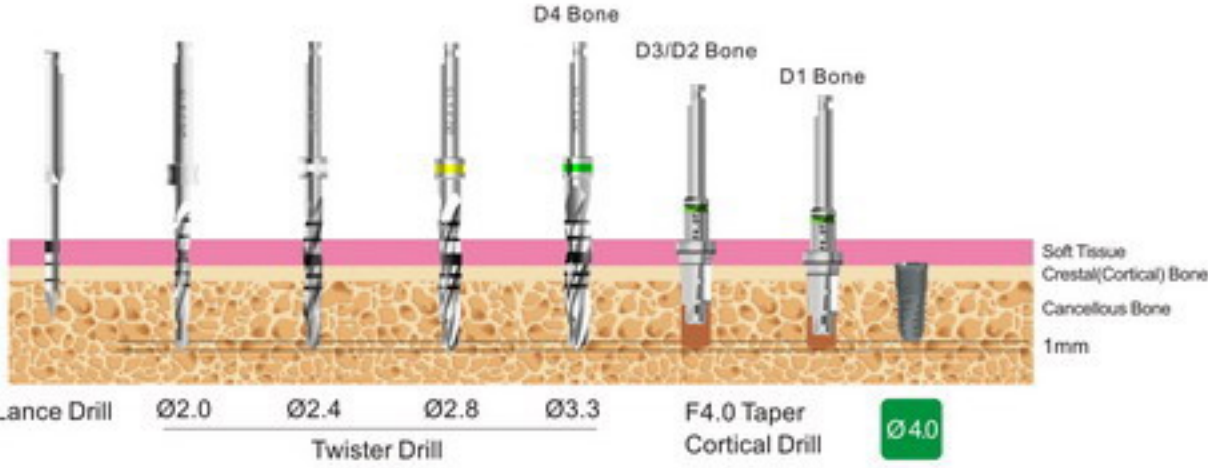

## Fixture 4.5x10mm

- D4 Bone** Lance Drill → Ø2.0mm Twister Drill → Ø2.4 Twister Drill → 2.8 Twister Drill → Ø3.3 Twister Drill → Ø3.8 Twister Drill (Drilling to half depth)
- D3/D2 Bone** Lance Drill → Ø2.0mm Twister Drill → Ø2.4 Twister Drill → 2.8 Twister Drill → Ø3.3 Twister Drill → Ø3.8 Twister Drill → F4.5 Taper Cortical Drill (Under the black laser line)
- D1 Bone** Lance Drill → Ø2.0mm Twister Drill → Ø2.4 Twister Drill → 2.8 Twister Drill → Ø3.3 Twister Drill → Ø3.8 Twister Drill → F4.5 Taper Cortical Drill (Up to stopper)

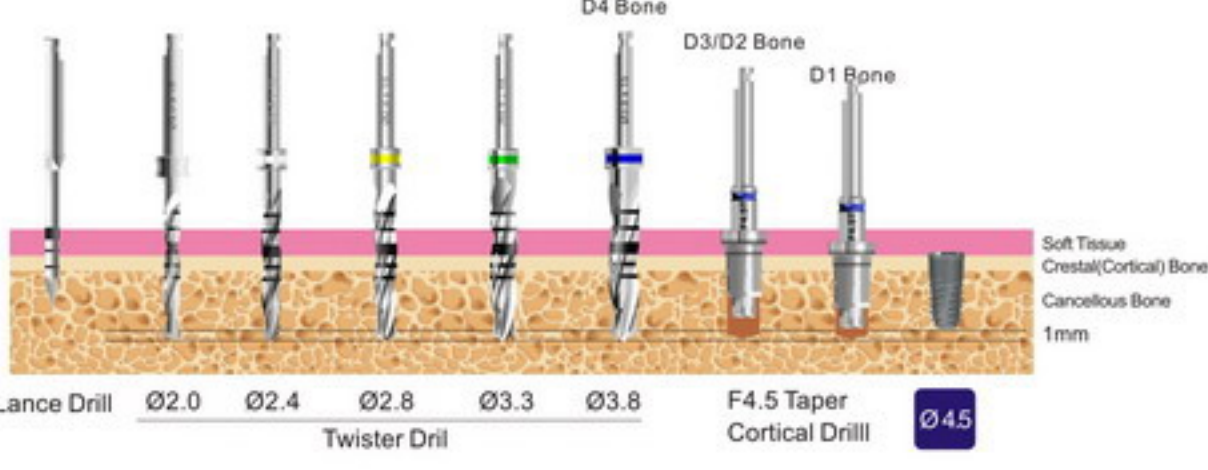

## Fixture 5.0x10mm

- D4 Bone** Lance Drill → Ø2.0mm Twister Drill → Ø2.4 Twister Drill → 2.8 Twister Drill → Ø3.3 Twister Drill → Ø3.8 Twister Drill → Ø4.3 Twister Drill (Drilling to half depth)
- D3/D2 Bone** Lance Drill → Ø2.0mm Twister Drill → Ø2.4 Twister Drill → Ø2.8 Twister Drill → Ø3.3 Twister Drill → Ø3.8 Twister Drill → Ø4.3 Twister Drill → F5.0 Taper Cortical Drill (Under the black laser line)
- D1 Bone** Lance Drill → Ø2.0mm Twister Drill → Ø2.4 Twister Drill → Ø2.8 Twister Drill → Ø3.3 Twister Drill → Ø3.8 Twister Drill → Ø4.3 Twister Drill → F5.0 Taper Cortical Drill (Up to stopper)

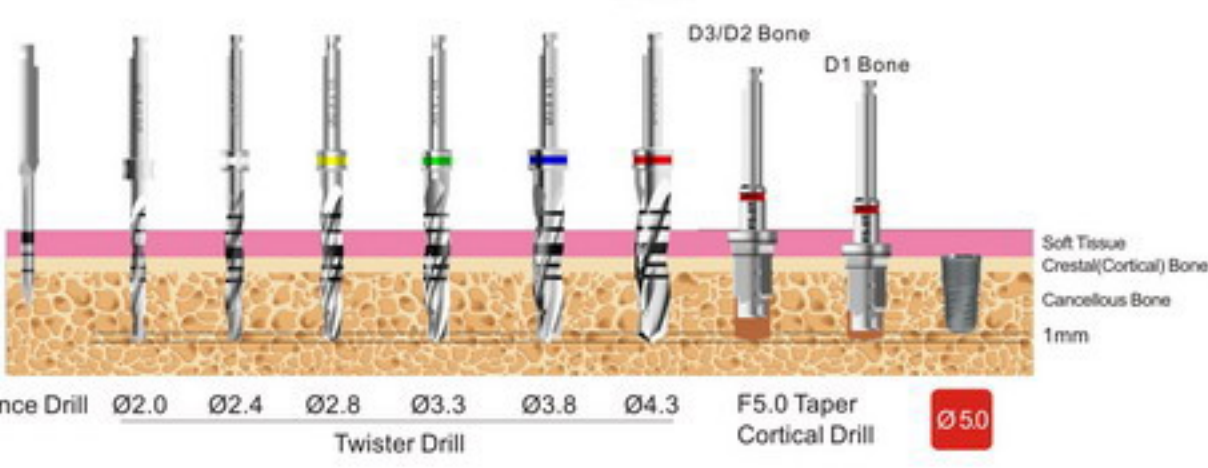

The above surgical sequences are recommended for conventional two-stage implantation. For flapless, immediate placement, immediate loading, or other surgical procedures, please modify the procedures upon your clinical judgment.



# SB-II TAPER KIT DRILLING SEQUENCE

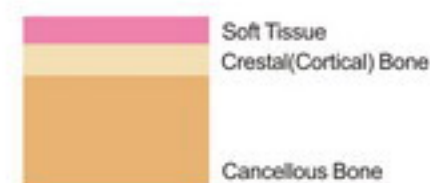

## Fixture 3.0x10mm

**D4 Bone** Lance Drill → Ø2.0mm Twist Drill → F3.0 Taper Drill

**D3/D2 Bone** Lance Drill → Ø2.0mm Twist Drill → F3.0 Taper Drill

**D1 Bone** Lance Drill → Ø2.0mm Twist Drill → F3.0 Taper Drill  
→ F3.0 Taper Cortical Drill

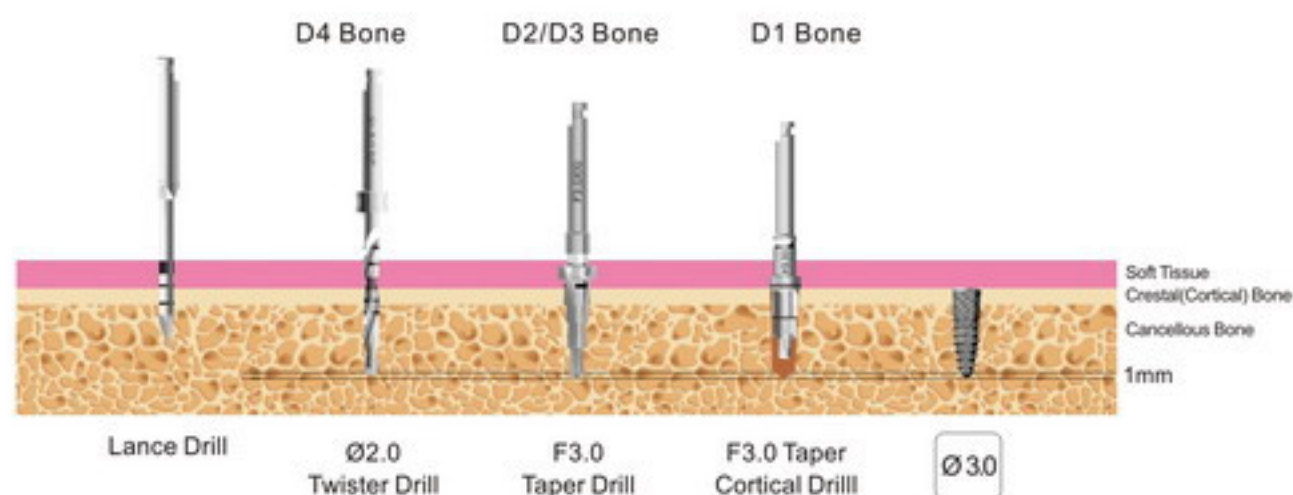

## Fixture 3.5x10mm

**D4 Bone** Lance Drill → Ø2.0mm Twister Drill → F3.0 Taper Drill

**D3/D2 Bone** Lance Drill → Ø2.0mm Twister Drill → F3.0 Taper Drill  
→ F3.5 Taper Drill

**D1 Bone** Lance Drill → Ø2.0mm Twister Drill → F3.0 Taper Drill  
→ F3.5 Taper Drill → F3.5 Taper Cortical Drill

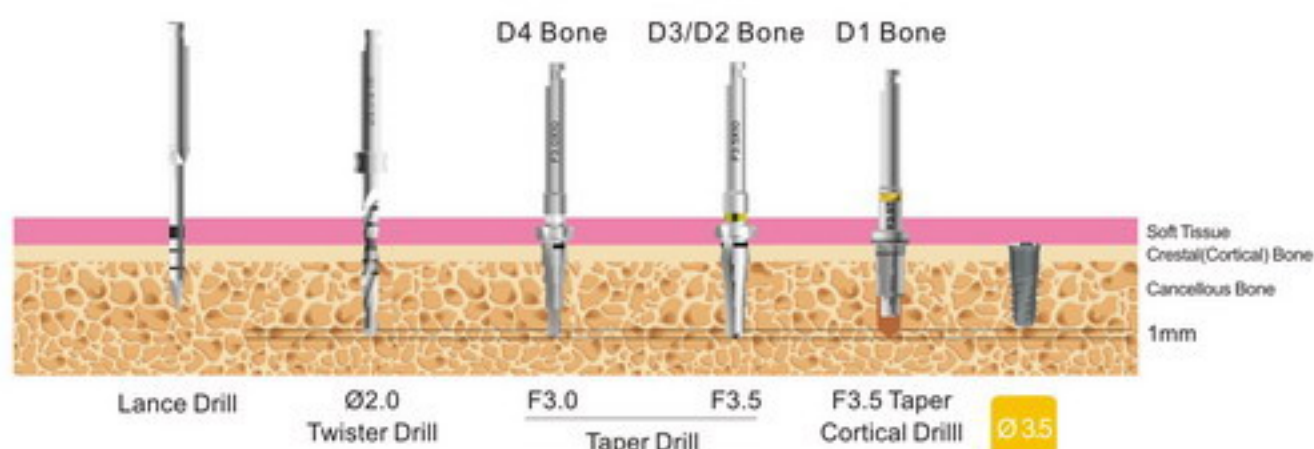

## Fixture 4.0x10mm

**D4 Bone** Lance Drill → Ø2.0mm Twister Drill → F3.0 Taper Drill  
→ F3.5 Taper Drill

**D3/D2 Bone** Lance Drill → Ø2.0mm Twister Drill → F3.0 Taper Drill  
→ F3.5 Taper Drill → F4.0 Taper Drill

**D1 Bone** Lance Drill → Ø2.0mm Twister Drill → F3.0 Taper Drill  
→ F3.5 Taper Drill → F4.0 Taper Drill → F4.0 Taper Cortical Drill

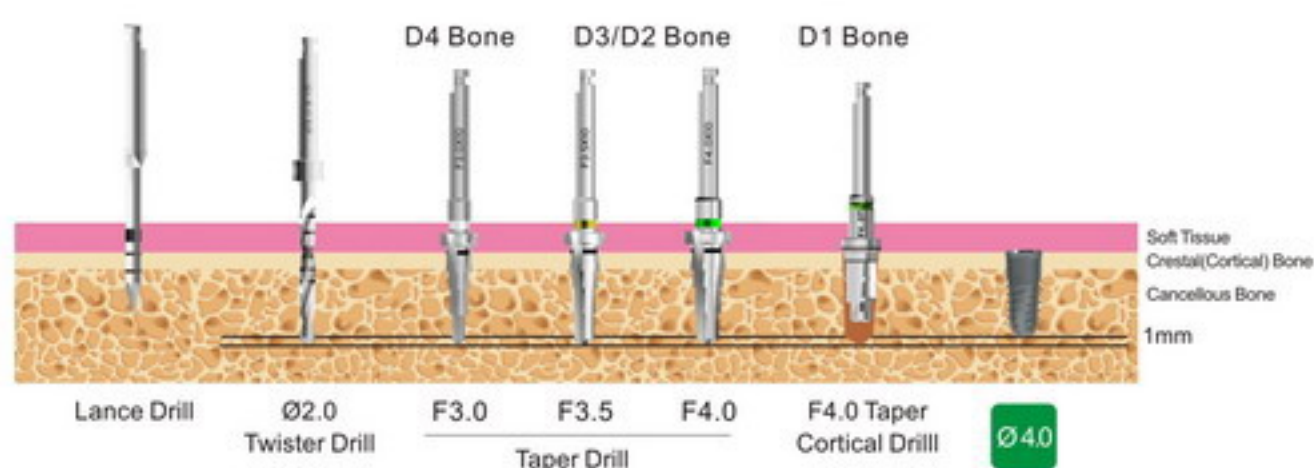

## Fixture 4.5x10mm

**D4 Bone** Lance Drill → Ø2.0mm Twister Drill → F3.0 Taper Drill  
→ F3.5 Taper Drill → F4.0 Taper Drill

**D3/D2 Bone** Lance Drill → Ø2.0mm Twister Drill → F3.0 Taper Drill  
→ F3.5 Taper Drill → F4.0 Taper Drill → F4.5 Taper Drill

**D1 Bone** Lance Drill → Ø2.0mm Twister Drill → F3.0 Taper Drill  
→ F3.5 Taper Drill → F4.0 Taper Drill → F4.5 Taper Drill  
→ F4.5 Taper Cortical Drill

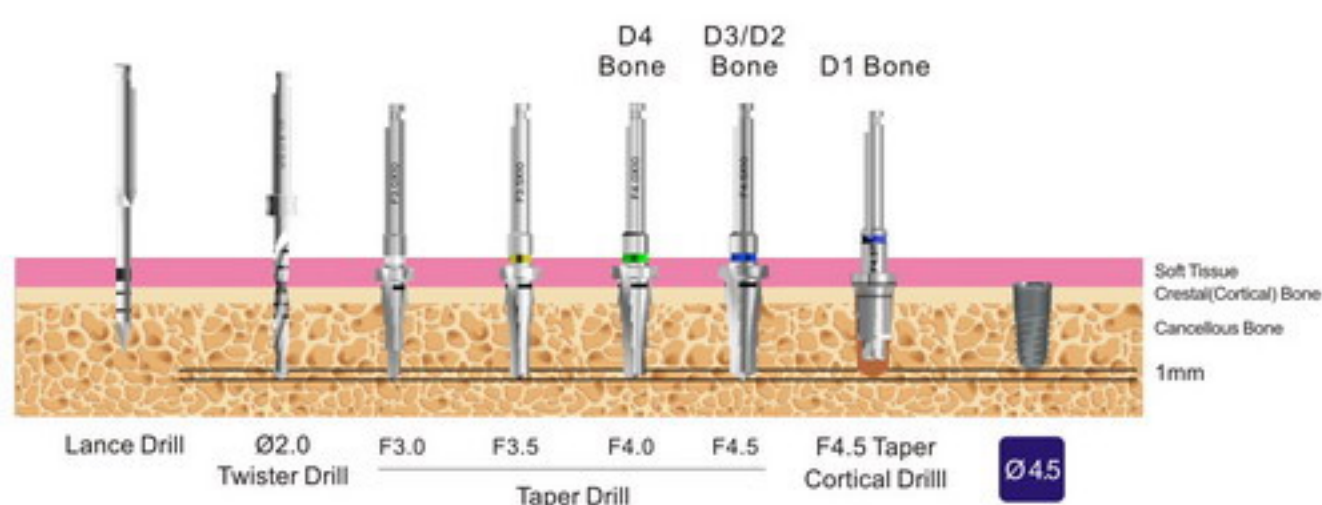

## Fixture 5.0x10mm

**D4 Bone** Lance Drill → Ø2.0mm Twister Drill → F3.0 Taper Drill  
→ F3.5 Taper Drill → F4.0 Taper Drill → F4.5 Taper Drill

**D3/D2 Bone** Lance Drill → Ø2.0mm Twister Drill → F3.0 Taper Drill  
→ F3.5 Taper Drill → F4.0 Taper Drill → F4.5 Taper Drill  
→ F5.0 Taper Drill

**D1 Bone** Lance Drill → Ø2.0mm Twister Drill → F3.0 Taper Drill  
→ F3.5 Taper Drill → F4.0 Taper Drill → F4.5 Taper Drill  
→ F5.0 Taper Drill → F5.0 Taper Cortical Drill

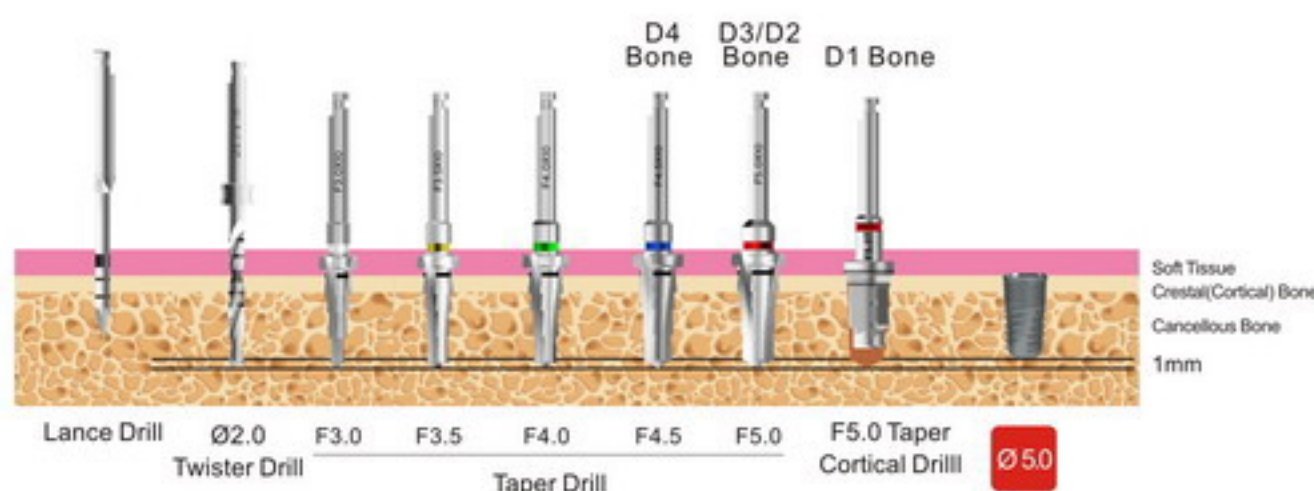

The above surgical sequences are recommended for conventional two-stage implantation. For flapless, immediate placement, immediate loading, or other surgical procedures, please modify the procedures upon your clinical judgment.



# Implant Fixture

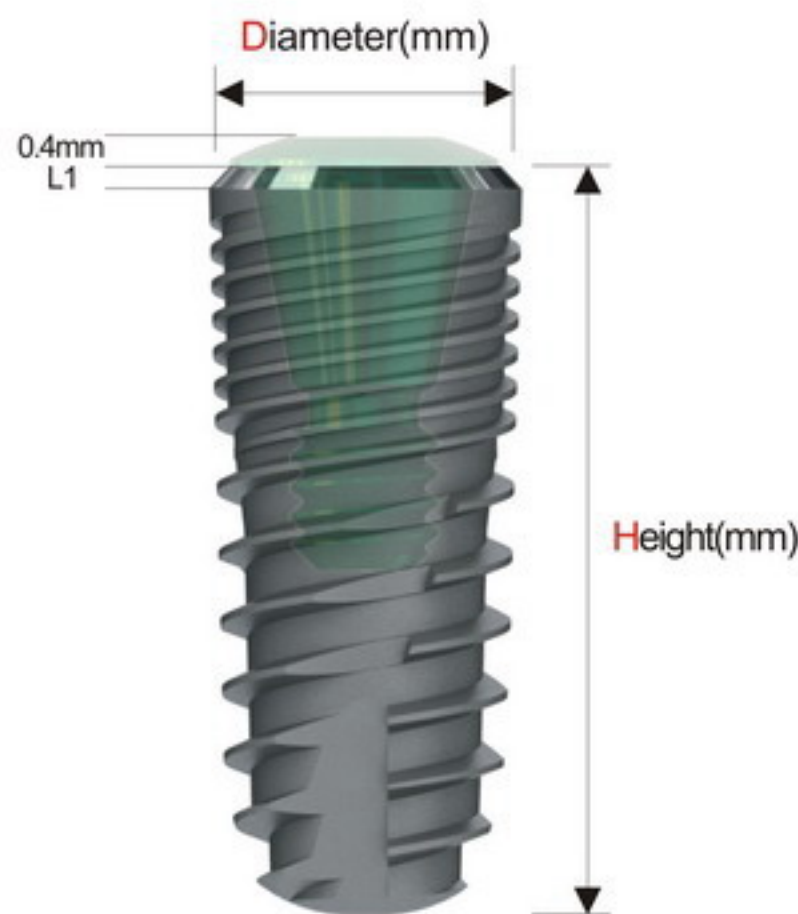

Fixture Specification (unit:mm)

	Ø3.0	Ø3.5	Ø4.0	Ø4.5	Ø5.0
Diameter	Ø3.0	Ø3.5	Ø4.0	Ø4.5	Ø5.0
Inter Hex	2.1	2.1	2.5	2.5	2.5
Neck Diameter	3.3	3.7	4.2	4.6	5.1
Bottom Diameter	2.2	2.5	2.8	3.1	3.7
L1	0.3	0.3	0.3	0.3	0.3

## Narrow

D	H	REF No.
3.0	10	SBN 3010
3.0	11.5	SBN 3011
3.0	13.0	SBN 3013
3.0	15.0	SBN 3015

D	H	REF No.
3.5	8.5	SBN 3508
3.5	10.0	SBN 3510
3.5	11.5	SBN 3511
3.5	13.0	SBN 3513
3.5	15.0	SBN 3515

## Standard

D	H	REF No.
4.0	7.0	SBS 4007
4.0	8.5	SBS 4008
4.0	10.0	SBS 4010
4.0	11.5	SBS 4011
4.0	13.0	SBS 4013
4.0	15.0	SBS 4015

D	H	REF No.
4.5	7.0	SBS 4507
4.5	8.5	SBS 4508
4.5	10.0	SBS 4510
4.5	11.5	SBS 4511
4.5	13.0	SBS 4513
4.5	15.0	SBS 4515

D	H	REF No.
5.0	7.0	SBS 5007
5.0	8.5	SBS 5008
5.0	10.0	SBS 5010
5.0	11.5	SBS 5011
5.0	13.0	SBS 5013
5.0	15.0	SBS 5015

## Cover Screw



Type	Narrow	Standard
REF No.	SBCS35(I)	SBCS40

- ◎Cover Screw and Fixture are within the same vial
- ◎Ø3.0 / Ø3.5 Fixture:Purple
- ◎Ø4.0,Ø4.5, Ø5.0 fixture:Green
- ◎Use a 1.2 Hand/Torque driver
- ◎Recommended installation:10 Ncm



# Healing Abutment

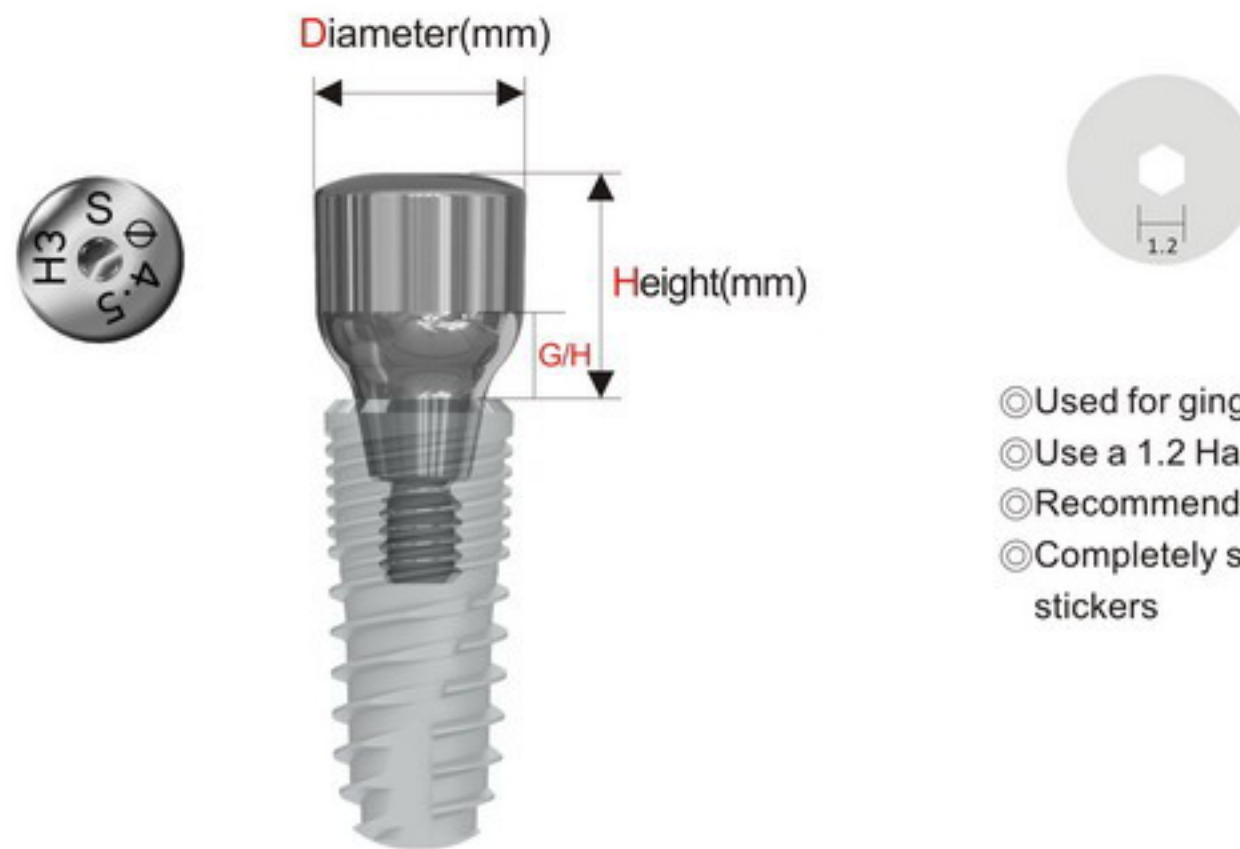

- ⊙ Used for gingival forming
- ⊙ Use a 1.2 Hand / Torque Hex Driver
- ⊙ Recommended installation: 10Ncm
- ⊙ Completely sterilized, with irradiation indication stickers

## For **Narrow** (Ø3.0 / Ø3.5) Fixtures

D	H	G/H	REF No.
4.5	3.0	1.0	SBHAN 453(I)
4.5	5.0	2.0	SBHAN 455(I)
4.5	7.0	3.0	SBHAN 457(I)
5.5	3.0	1.0	SBHAN 553(I)
5.5	6.0	3.0	SBHAN 556(I)

## For **Standard** (Ø4.0/Ø4.5/Ø5.0) Fixtures

D	H	G/H	REF No.
4.5	3.0	1.0	SBHAS 453
4.5	5.0	2.0	SBHAS 455
4.5	7.0	3.0	SBHAS 457

D	H	G/H	REF No.
5.5	3.0	1.0	SBHAS 553
5.5	5.0	2.0	SBHAS 555
5.5	7.0	3.0	SBHAS 557

D	H	G/H	REF No.
6.5	3.0	1.0	SBHAS 653
6.5	5.0	2.0	SBHAS 655
6.5	7.0	3.0	SBHAS 657

D	H	G/H	REF No.
7.5	3.0	1.0	SBHAS 753
7.5	5.0	2.0	SBHAS 755
7.5	7.0	3.0	SBHAS 757



Use a 1.2 Hand/  
Torque Driver

## Thin Abutment For **Narrow**



D	4.0	4.0	4.0
H(Narrow)	4.0	6.0	8.0
REF No.	SBHAN 402(I)	SBHAN 404(I)	SBHAN 406(I)

## Thin Abutment For **Standard**



D	4.0	4.0	4.0
H(Standard)	4.0	6.0	8.0
REF No.	SBHA 402	SBHA 404	SBHA 406



# Fixed Abutment

## Narrow

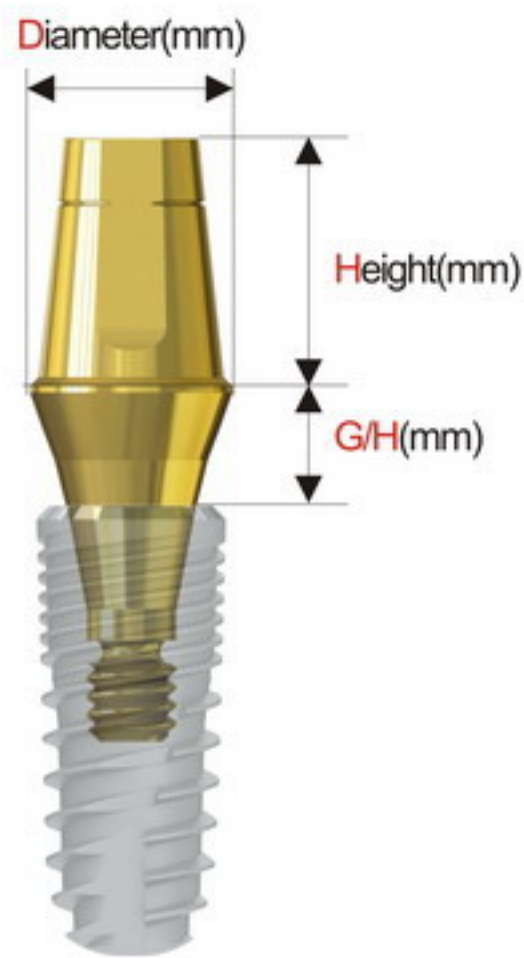

- ⊙ Cement type prosthesis
- ⊙ Transected interface itself prevents the rotation
- ⊙ Ø4.0: Use the Fixed Piece / Torque Driver
- ⊙ Ø4.5: Use a 1.2 Hand / Torque Driver
- ⊙ Recommended installation: 30Ncm
- ⊙ Package content: Abutment + Protect Cap
- ⊙ Completely sterilized, with irradiation indication stickers



## Narrow For Ø3.0 / Ø3.5 Fixture

D	H	G/H	REF No.
4.0	4.0	1.0	SBFAN 4410(I)
4.0	4.0	2.0	SBFAN 4420(I)
4.0	4.0	3.0	SBFAN 4430(I)
4.0	4.0	4.0	SBFAN 4440(I)

D	H	G/H	REF No.
4.5	4.0	1.0	SBFAN 4411(I)
4.5	4.0	2.0	SBFAN 4421(I)
4.5	4.0	3.0	SBFAN 4431(I)
4.5	4.0	4.0	SBFAN 4441(I)

D	H	G/H	REF No.
4.0	5.5	1.0	SBFAN 4610(I)
4.0	5.5	2.0	SBFAN 4620(I)
4.0	5.5	3.0	SBFAN 4630(I)
4.0	5.5	4.0	SBFAN 4640(I)

D	H	G/H	REF No.
4.5	5.5	1.0	SBFAN 4611(I)
4.5	5.5	2.0	SBFAN 4621(I)
4.5	5.5	3.0	SBFAN 4631(I)
4.5	5.5	4.0	SBFAN 4641(I)

D	H	G/H	REF No.
4.0	7.0	1.0	SBFAN 4710(I)
4.0	7.0	2.0	SBFAN 4720(I)
4.0	7.0	3.0	SBFAN 4730(I)
4.0	7.0	4.0	SBFAN 4740(I)

D	H	G/H	REF No.
4.5	7.0	1.0	SBFAN 4711(I)
4.5	7.0	2.0	SBFAN 4721(I)
4.5	7.0	3.0	SBFAN 4731(I)
4.5	7.0	4.0	SBFAN 4741(I)



Ø4.0: Use a Fixed Torque driver

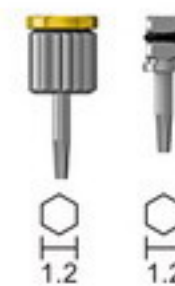

Ø4.5:  
Use a 1.2 Hand / Torque driver



# Fixed Abutment

## Standard

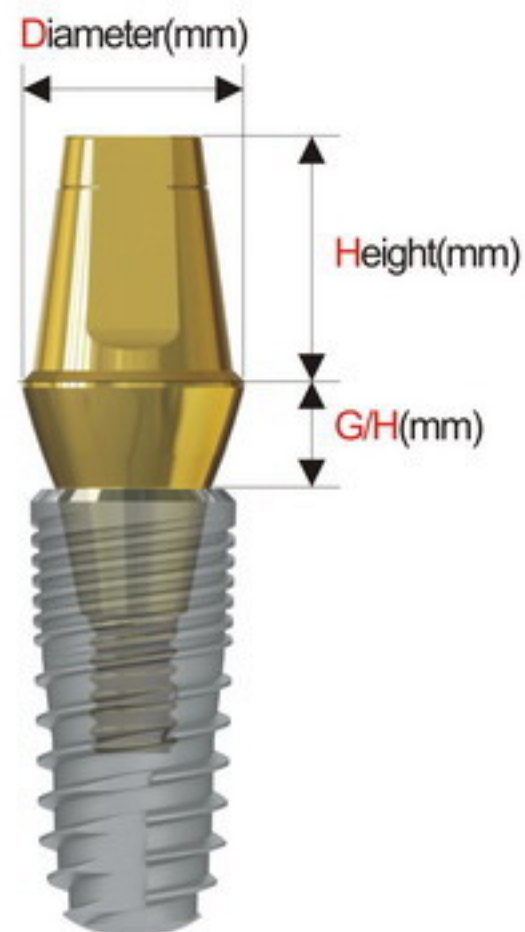

- ⊙ Cement type prosthesis
- ⊙ Transected interface itself prevents the rotation
- ⊙ Ø4.5/Ø5.0/Ø6.0 : Use a 1.2 Hand / Torque Hex Driver
- ⊙ Recommended installation: 30Ncm
- ⊙ Package content: Abutment + Protect Cap
- ⊙ Completely sterilized, with irradiation indication stickers

## Standard For Ø4.0/Ø4.5/Ø5.0 Fixture

D	H	G/H	REF No.
4.0	4.0	1.0	SBFA 4410
4.0	4.0	2.0	SBFA 4420
4.0	4.0	3.0	SBFA 4430
4.0	4.0	4.0	SBFA 4440
D	H	G/H	REF No.
4.0	5.5	1.0	SBFA 4610
4.0	5.5	2.0	SBFA 4620
4.0	5.5	3.0	SBFA 4630
4.0	5.5	4.0	SBFA 4640
D	H	G/H	REF No.
4.0	7.0	1.0	SBFA 4710
4.0	7.0	2.0	SBFA 4720
4.0	7.0	3.0	SBFA 4730
4.0	7.0	4.0	SBFA 4740

D	H	G/H	REF No.
4.5	4.0	1.0	SBFA 4411
4.5	4.0	2.0	SBFA 4421
4.5	4.0	3.0	SBFA 4431
4.5	4.0	4.0	SBFA 4441
D	H	G/H	REF No.
4.5	5.5	1.0	SBFA 4611
4.5	5.5	2.0	SBFA 4621
4.5	5.5	3.0	SBFA 4631
4.5	5.5	4.0	SBFA 4641
D	H	G/H	REF No.
4.5	7.0	1.0	SBFA 4711
4.5	7.0	2.0	SBFA 4721
4.5	7.0	3.0	SBFA 4731
4.5	7.0	4.0	SBFA 4741

D	H	G/H	REF No.
5.0	4.0	1.0	SBFA 5410
5.0	4.0	2.0	SBFA 5420
5.0	4.0	3.0	SBFA 5430
5.0	4.0	4.0	SBFA 5440
D	H	G/H	REF No.
5.0	5.5	1.0	SBFA 5610
5.0	5.5	2.0	SBFA 5620
5.0	5.5	3.0	SBFA 5630
5.0	5.5	4.0	SBFA 5640
D	H	G/H	REF No.
5.0	7.0	1.0	SBFA 5710
5.0	7.0	2.0	SBFA 5720
5.0	7.0	3.0	SBFA 5730
5.0	7.0	4.0	SBFA 5740

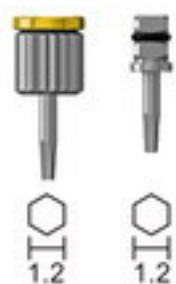

Ø4.5/Ø5.0/Ø6.0:  
Use a 1.2 Hand /  
Torque driver

D	H	G/H	REF No.
6.0	4.0	1.0	SBFA 6410
6.0	4.0	2.0	SBFA 6420
6.0	4.0	3.0	SBFA 6430
6.0	4.0	4.0	SBFA 6440
D	H	G/H	REF No.
6.0	5.5	1.0	SBFA 6610
6.0	5.5	2.0	SBFA 6620
6.0	5.5	3.0	SBFA 6630
6.0	5.5	4.0	SBFA 6640
D	H	G/H	REF No.
6.0	7.0	1.0	SBFA 6710
6.0	7.0	2.0	SBFA 6720
6.0	7.0	3.0	SBFA 6730
6.0	7.0	4.0	SBFA 6740

D	H	G/H	REF No.
7.0	5.5	1.0	SBFA 7610
7.0	5.5	2.0	SBFA 7620
7.0	5.5	3.0	SBFA 7630
7.0	5.5	4.0	SBFA 7640



# Fixed Protect Cap

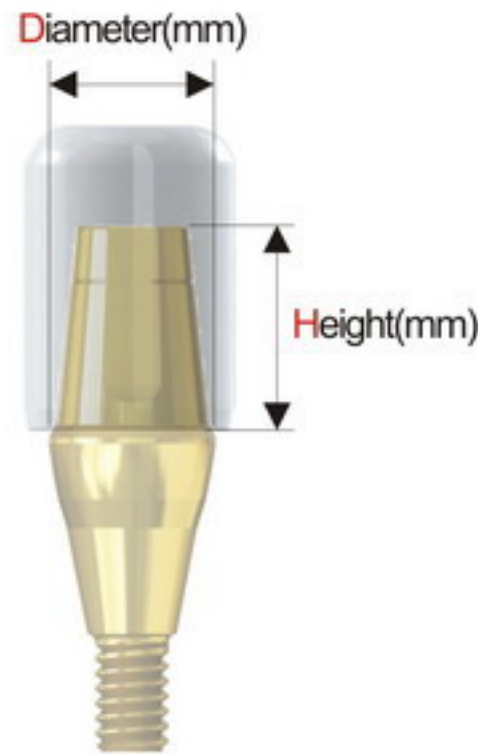

- ⊙ Used for protection of the Fixed Abutment
- ⊙ Easy installation
- ⊙ H & D are inner dimensions to match the corresponding abutment dimensions
- ⊙ Material : Polypropylene (PP)

D	H	REF No.
4.0	4.0	SBFPC 440
4.0	5.5	SBFPC 460
4.0	7.0	SBFPC 470

D	H	REF No.
4.5	4.0	SBFPC 441
4.5	5.5	SBFPC 461
4.5	7.0	SBFPC 471

D	H	REF No.
5.0	4.0	SBFPC 540
5.0	5.5	SBFPC 560
5.0	7.0	SBFPC 570

D	H	REF No.
6.0	4.0	SBFPC 640
6.0	5.5	SBFPC 660
6.0	7.0	SBFPC 670

D	H	REF No.
7.0	5.5	SBFPC 760

# Fixed Burn-out Cylinder

## Single Type

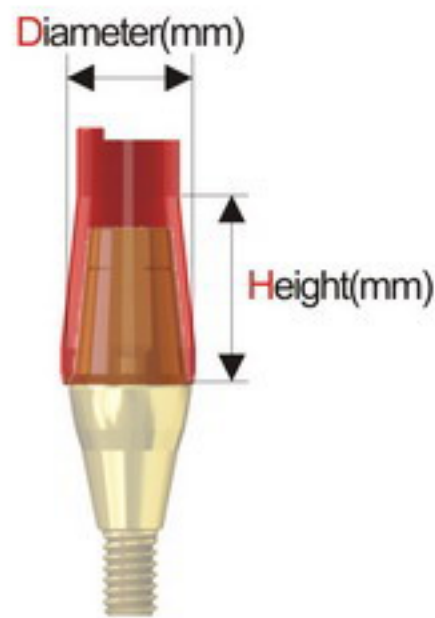

## Bridge Type

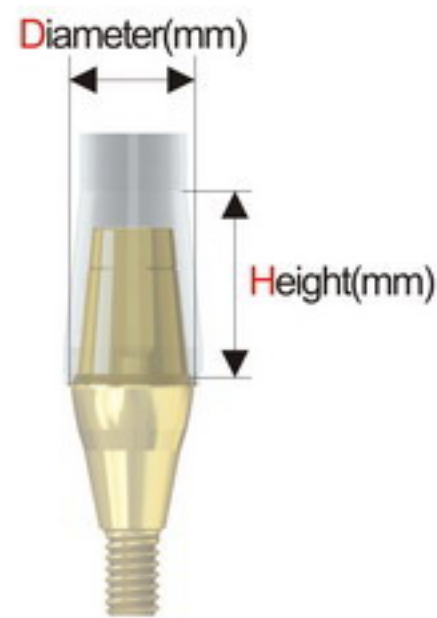

- ⊙ Used for wax molding
- ⊙ Color coding for different cases
- ⊙ Single Type: Red
- ⊙ Bridge Type: White
- ⊙ Material: POM

D	H	REF No.
4.0	7.0	SBFB 400S
4.5	7.0	SBFB 450S

D	H	REF No.
4.0	7.0	SBFB 400B
4.5	7.0	SBFB 450B

D	H	REF No.
5.0	7.0	SBFB 500S

D	H	REF No.
5.0	7.0	SBFB 500B

D	H	REF No.
6.0	7.0	SBFB 600S
7.0	7.0	SBFB 700S

D	H	REF No.
6.0	7.0	SBFB 600B
7.0	7.0	SBFB 700B



# Fixed Impression Coping

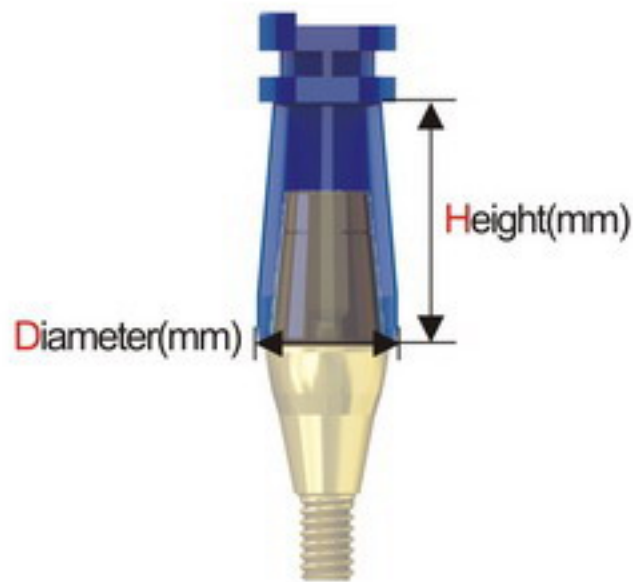

- ⊙ Used for taking an impression of Fixed Abutment
- ⊙ Easy installation
- ⊙ H & D are inner dimensions to match the corresponding abutment dimensions
- ⊙ Material : PP

D	H	REF No.
4.0	9.0	SBFIC 470S
4.5	9.0	SBFIC 471S

D	H	REF No.
5.0	9.0	SBFIC 570S

D	H	REF No.
6.0	9.0	SBFIC 670S
7.0	9.0	SBFIC 760S

# Fixed Lab Analog

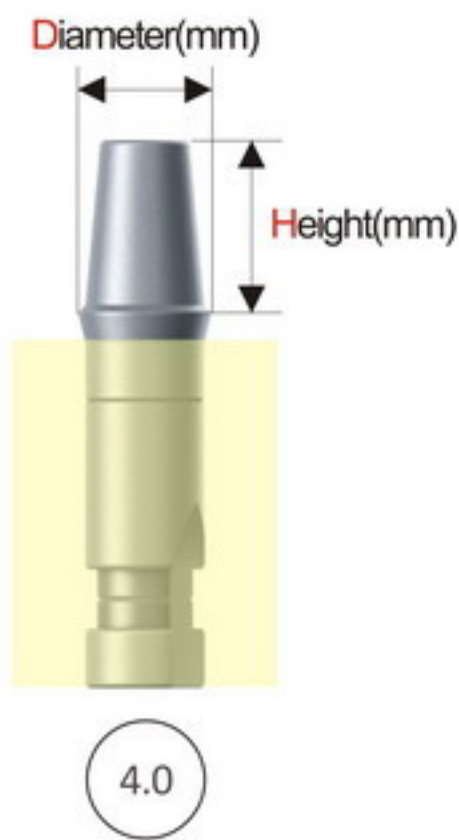

- ⊙ Place into the cast for model fabrication
- ⊙ Color coding for individual lengths:  
4.0mm(no scale), 5.5mm(1 scale), 7.0mm(2 scales)
- ⊙ Material : Ti6Al4V

D	H	Color	REF No.
4.0	4.0	Yellow	SBFLA 440
4.0	5.5	Gray	SBFLA 460
4.0	7.0	Blue	SBFLA 470
4.5	4.0	Yellow	SBFLA 441
4.5	5.5	Gray	SBFLA 461
4.5	7.0	Blue	SBFLA 471

D	H	Color	REF No.
5.0	4.0	Yellow	SBFLA 540
5.0	5.5	Gray	SBFLA 560
5.0	7.0	Blue	SBFLA 570

D	H	Color	REF No.
6.0	4.0	Yellow	SBFLA 640
6.0	5.5	Gray	SBFLA 660
6.0	7.0	Blue	SBFLA 670
7.0	5.5	Gray	SBFLA 760



# Dual Abutment / Hex Type

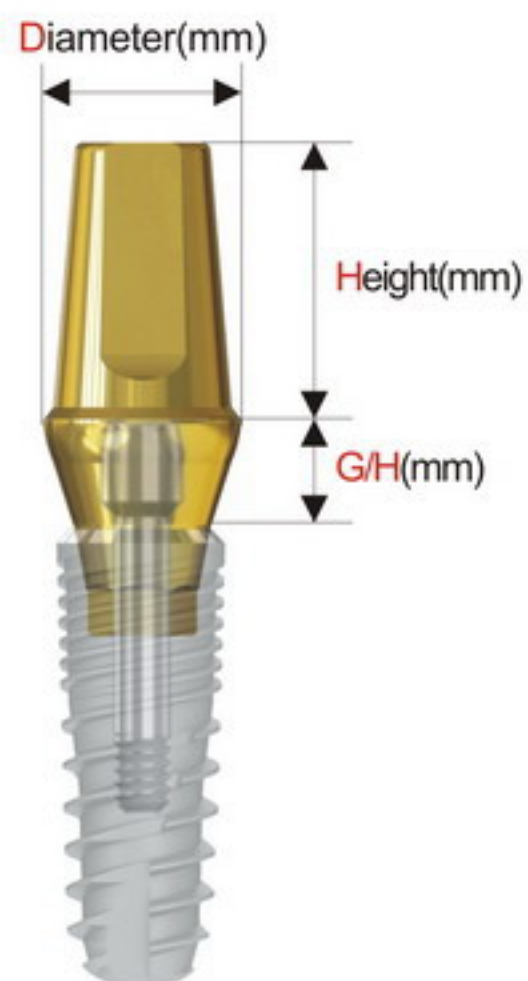

- ⊙ Cement type prosthesis
- ⊙ Transected interface itself prevents the rotation
- ⊙ Use a 1.2 Hand / Torque Hex Driver
- ⊙ Recommended installation : 25Ncm
- ⊙ Package content: Abutment + Ti Screw
- ⊙ Completely sterilized, with irradiation indication stickers

## Narrow For Ø3.0 / Ø3.5 Fixture

D	H	G/H	REF No.
4.5	5.5	1.0	SBDN 4610(I)
4.5	5.5	2.0	SBDN 4620(I)
4.5	5.5	3.0	SBDN 4630(I)
4.5	5.5	4.0	SBDN 4640(I)
4.5	5.5	5.0	SBDN 4650(I)

D	H	G/H	REF No.
5.0	5.5	1.0	SBDN 5610(I)
5.0	5.5	2.0	SBDN 5620(I)
5.0	5.5	3.0	SBDN 5630(I)
5.0	5.5	4.0	SBDN 5640(I)



Use a 1.2 Hand/  
Torque Driver



F3.0
REF No.
SBABSN(I)



# Dual Abutment / Hex Type

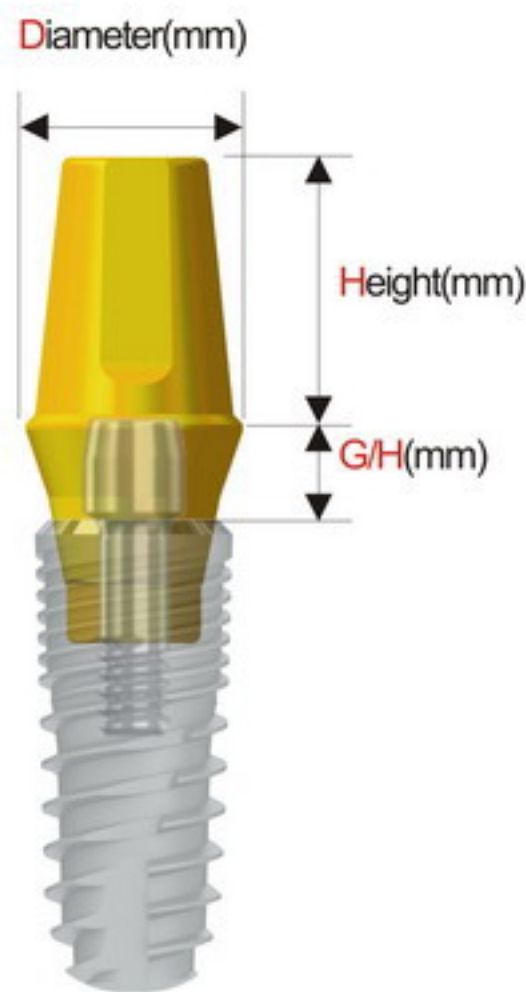

- ⊙ Cement type prosthesis
- ⊙ Transected interface itself prevents the rotation
- ⊙ Use a 1.2 Hand / Torque Hex Driver
- ⊙ Recommended installation: 25Ncm
- ⊙ Package content: Abutment + Ti Screw
- ⊙ Completely sterilized, with irradiation indication stickers

## Standard For $\varnothing 4.0/\varnothing 4.5/\varnothing 5.0$ Fixture

D	H	G/H	REF No.
4.5	5.5	1.0	SBDS 4610
4.5	5.5	2.0	SBDS 4620
4.5	5.5	3.0	SBDS 4630
4.5	5.5	4.0	SBDS 4640
4.5	5.5	5.0	SBDS 4650

D	H	G/H	REF No.
5.0	4.0	1.0	SBDS 5410
5.0	4.0	2.0	SBDS 5420
5.0	4.0	3.0	SBDS 5430
5.0	4.0	4.0	SBDS 5440
5.0	4.0	5.0	SBDS 5450

D	H	G/H	REF No.
6.0	4.0	1.0	SBDS 6410
6.0	4.0	2.0	SBDS 6420
6.0	4.0	3.0	SBDS 6430
6.0	4.0	4.0	SBDS 6440
6.0	4.0	5.0	SBDS 6450



Use a 1.2 Hand/  
Torque Driver



REF No.
SBABSS

D	H	G/H	REF No.
5.0	5.5	1.0	SBDS 5610
5.0	5.5	2.0	SBDS 5620
5.0	5.5	3.0	SBDS 5630
5.0	5.5	4.0	SBDS 5640
5.0	5.5	5.0	SBDS 5650

D	H	G/H	REF No.
6.0	5.5	1.0	SBDS 6610
6.0	5.5	2.0	SBDS 6620
6.0	5.5	3.0	SBDS 6630
6.0	5.5	4.0	SBDS 6640
6.0	5.5	5.0	SBDS 6650

D	H	G/H	REF No.
5.0	7.0	1.0	SBDS 5710
5.0	7.0	2.0	SBDS 5720
5.0	7.0	3.0	SBDS 5730
5.0	7.0	4.0	SBDS 5740
5.0	7.0	5.0	SBDS 5750

D	H	G/H	REF No.
6.0	7.0	1.0	SBDS 6710
6.0	7.0	2.0	SBDS 6720
6.0	7.0	3.0	SBDS 6730
6.0	7.0	4.0	SBDS 6740
6.0	7.0	5.0	SBDS 6750

D	H	G/H	REF No.
7.0	5.5	1.0	SBDS 7610
7.0	5.5	2.0	SBDS 7620
7.0	5.5	3.0	SBDS 7630
7.0	5.5	4.0	SBDS 7640
7.0	5.5	4.0	SBDS 7650



# Dual Abutment / Non-Hex Type

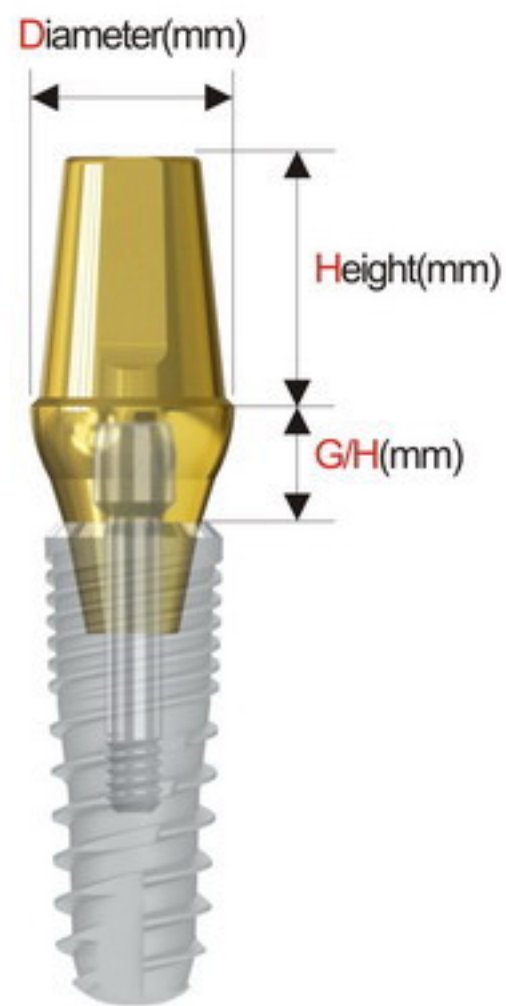

- ⊙ Cement type prosthesis
- ⊙ Used for bridge restoration
- ⊙ Use a 1.2 Hand / Torque Hex Driver
- ⊙ Recommended installation : 25Ncm
- ⊙ Package content: Abutment + Ti Screw
- ⊙ Completely sterilized, with irradiation indication stickers

## For Ø3.0 / Ø3.5 Fixture

D	H	G/H	REF No.
4.5	5.5	1.0	SBDN 4610N(I)
4.5	5.5	2.0	SBDN 4620N(I)
4.5	5.5	3.0	SBDN 4630N(I)
4.5	5.5	4.0	SBDN 4640N(I)
4.5	5.5	5.0	SBDN 4650N(I)

D	H	G/H	REF No.
5.0	5.5	1.0	SBDN 5610N(I)
5.0	5.5	2.0	SBDN 5620N(I)
5.0	5.5	3.0	SBDN 5630N(I)
5.0	5.5	4.0	SBDN 5640N(I)



Use a 1.2 Hand/  
Torque Driver



F3.0
REF No.
SBABSN(I)



# Dual Abutment / Non-Hex Type



- ⊙ Cement type prosthesis
- ⊙ Used for bridge restoration
- ⊙ Use a 1.2 Hand / Torque Hex Driver
- ⊙ Recommended installation: 25Ncm
- ⊙ Package content: Abutment + Ti Screw
- ⊙ Completely sterilized, with irradiation indication stickers

## Standard For $\varnothing 4.0/\varnothing 4.5/\varnothing 5.0$ Fixture

D	H	G/H	REF No.
4.5	5.5	1.0	SBDS 4610N
4.5	5.5	2.0	SBDS 4620N
4.5	5.5	3.0	SBDS 4630N
4.5	5.5	4.0	SBDS 4640N
4.5	5.5	5.0	SBDS 4650N

D	H	G/H	REF No.
5.0	4.0	1.0	SBDS 5410N
5.0	4.0	2.0	SBDS 5420N
5.0	4.0	3.0	SBDS 5430N
5.0	4.0	4.0	SBDS 5440N
5.0	4.0	5.0	SBDS 5450N

D	H	G/H	REF No.
6.0	4.0	1.0	SBDS 6410N
6.0	4.0	2.0	SBDS 6420N
6.0	4.0	3.0	SBDS 6430N
6.0	4.0	4.0	SBDS 6440N
6.0	4.0	5.0	SBDS 6450N

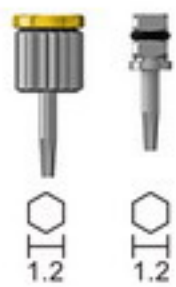

Use a 1.2 Hand/  
Torque Driver



REF No.
SBABSS

D	H	G/H	REF No.
5.0	5.5	1.0	SBDS 5610N
5.0	5.5	2.0	SBDS 5620N
5.0	5.5	3.0	SBDS 5630N
5.0	5.5	4.0	SBDS 5640N
5.0	5.5	5.0	SBDS 5650N

D	H	G/H	REF No.
6.0	5.5	1.0	SBDS 6610N
6.0	5.5	2.0	SBDS 6620N
6.0	5.5	3.0	SBDS 6630N
6.0	5.5	4.0	SBDS 6640N
6.0	5.5	5.0	SBDS 6650N

D	H	G/H	REF No.
5.0	7.0	1.0	SBDS 5710N
5.0	7.0	2.0	SBDS 5720N
5.0	7.0	3.0	SBDS 5730N
5.0	7.0	4.0	SBDS 5740N
5.0	7.0	5.0	SBDS 5750N

D	H	G/H	REF No.
6.0	7.0	1.0	SBDS 6710N
6.0	7.0	2.0	SBDS 6720N
6.0	7.0	3.0	SBDS 6730N
6.0	7.0	4.0	SBDS 6740N
6.0	7.0	5.0	SBDS 6750N

D	H	G/H	REF No.
7.0	5.5	1.0	SBDS 7610N
7.0	5.5	2.0	SBDS 7620N
7.0	5.5	3.0	SBDS 7630N
7.0	5.5	4.0	SBDS 7640N
7.0	5.5	5.0	SBDS 7650N



# Angled Abutment

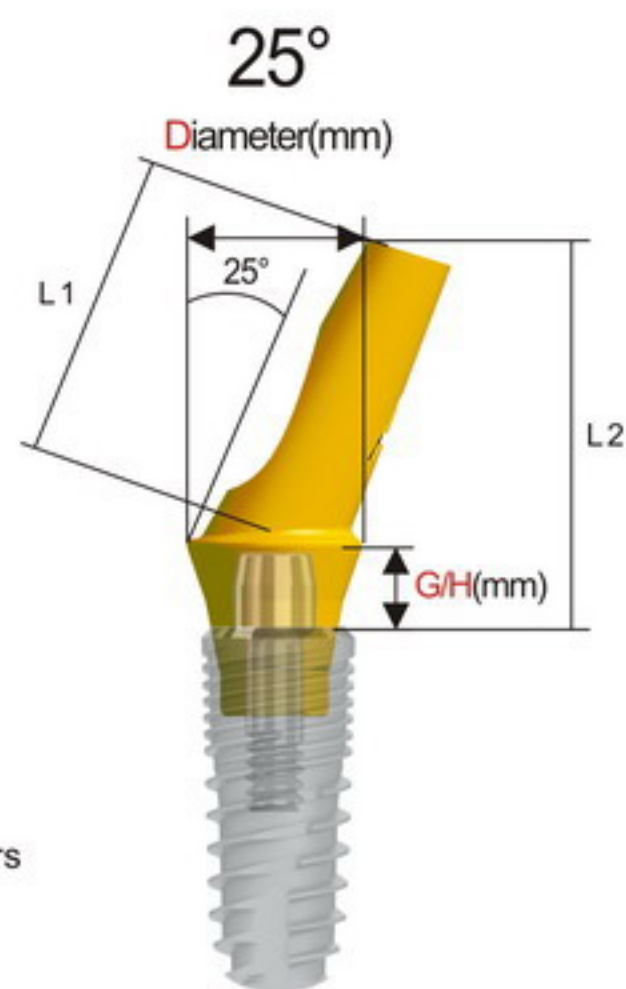
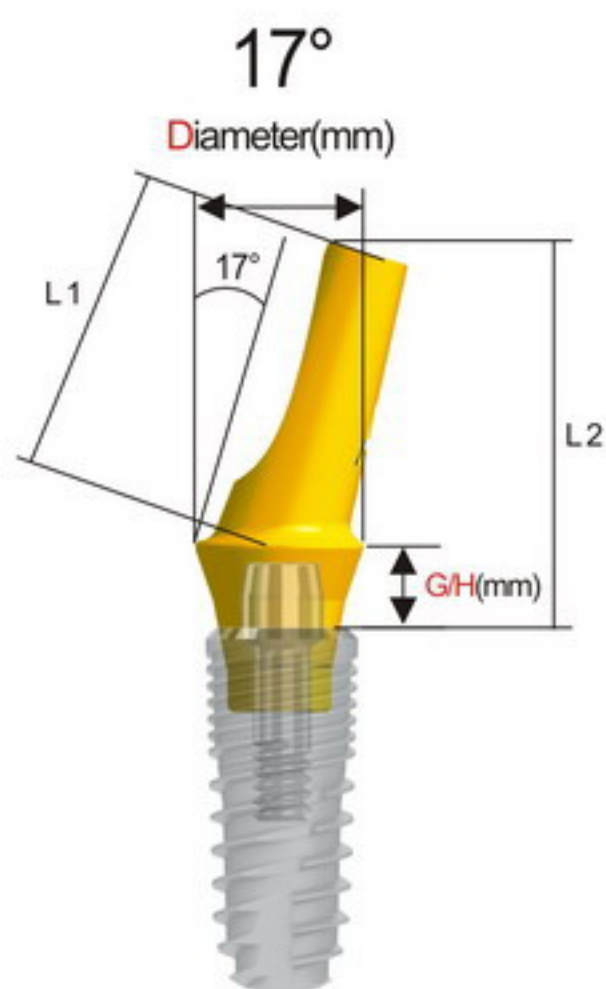

- ⊙ Used for corresponding the angle of prosthesis
- ⊙ Anodized surface evolves an esthetic outcome
- ⊙ Hex type : For single dental crown  
Non-Hex type : For multiple bridge crown
- ⊙ Use a 1.2 Hand / Torque Driver
- ⊙ Recommended installation: 25Ncm
- ⊙ Package Content: Abutment + Ti Screw
- ⊙ Completely sterilized, with irradiation indication stickers



## Narrow For Ø3.0 / Ø3.5 Fixture

D	G/H	Type	L1	L2	REF No.
4.3	2.0	A	8.1	10.3	SBAA 4320A(I)
4.3	2.0	B	8.1	10.3	SBAA 4320B(I)
4.3	2.0	N	8.1	10.3	SBAA 4320N(I)
4.3	4.0	A	8.1	12.03	SBAA 4340A(I)
4.3	4.0	B	8.1	12.03	SBAA 4340B(I)
4.3	4.0	N	8.1	12.03	SBAA 4340N(I)



## Narrow For Ø3.0 / Ø3.5 Fixture

D	G/H	Type	L1	L2	REF No.
4.3	2.0	A	8.19	9.71	SBAA 4320A25(I)
4.3	2.0	B	8.19	9.71	SBAA 4320B25(I)
4.3	2.0	N	8.19	9.71	SBAA 4320N25(I)
4.3	4.0	A	8.19	11.71	SBAA 4340A25(I)
4.3	4.0	B	8.19	11.71	SBAA 4340B25(I)
4.3	4.0	N	8.19	11.71	SBAA 4340N25(I)

## Standard

### For Ø4.0 / Ø4.5 / Ø5.0 Fixture

D	G/H	Type	L1	L2	REF No.
4.5	2.0	A	8.1	10.16	SBAA 4520A
4.5	2.0	B	8.1	10.16	SBAA 4520B
4.5	2.0	N	8.1	10.16	SBAA 4520N
4.5	4.0	A	8.1	12.16	SBAA 4540A
4.5	4.0	B	8.1	12.16	SBAA 4540B
4.5	4.0	N	8.1	12.16	SBAA 4540N
D	G/H	Type	L1	L2	REF No.
5.5	2.0	A	8.1	10.21	SBAA 5520A
5.5	2.0	B	8.1	10.21	SBAA 5520B
5.5	2.0	N	8.1	10.21	SBAA 5520N
5.5	4.0	A	8.1	12.21	SBAA 5540A
5.5	4.0	B	8.1	12.21	SBAA 5540B
5.5	4.0	N	8.1	12.21	SBAA 5540N

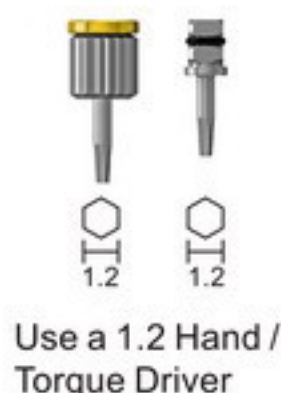

## Standard

### For Ø4.0 / Ø4.5 / Ø5.0 Fixture

D	G/H	Type	L1	L2	REF No.
4.5	2.0	A	8.18	9.83	SBAA 4520A25
4.5	2.0	B	8.18	9.83	SBAA 4520B25
4.5	2.0	N	8.18	9.83	SBAA 4520N25
4.5	4.0	A	8.18	11.83	SBAA 4540A25
4.5	4.0	B	8.18	11.83	SBAA 4540B25
4.5	4.0	N	8.18	11.83	SBAA 4540N25
D	G/H	Type	L1	L2	REF No.
5.5	2.0	A	8.18	9.9	SBAA 5520A25
5.5	2.0	B	8.18	9.9	SBAA 5520B25
5.5	2.0	N	8.18	9.9	SBAA 5520N25
5.5	4.0	A	8.18	11.9	SBAA 5540A25
5.5	4.0	B	8.18	11.9	SBAA 5540B25
5.5	4.0	N	8.18	11.9	SBAA 5540N25



# Fixture Pick-up Impression Coping

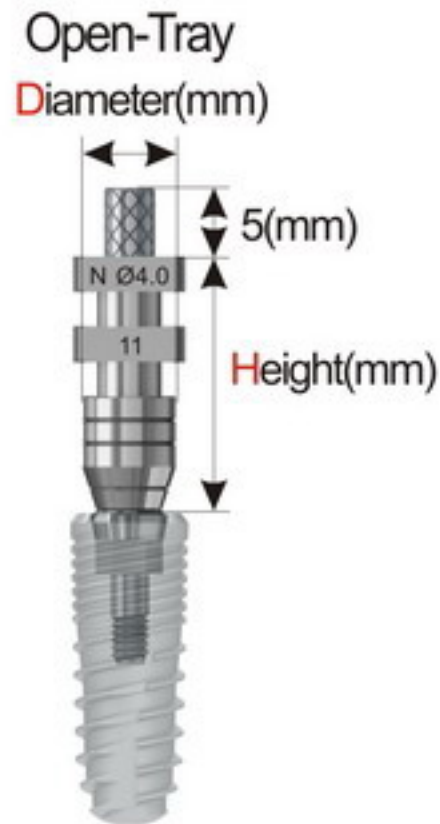

- ◎ Pick-up type for customized tray
- ◎ Package includes screw

# Fixture Transfer Impression Coping

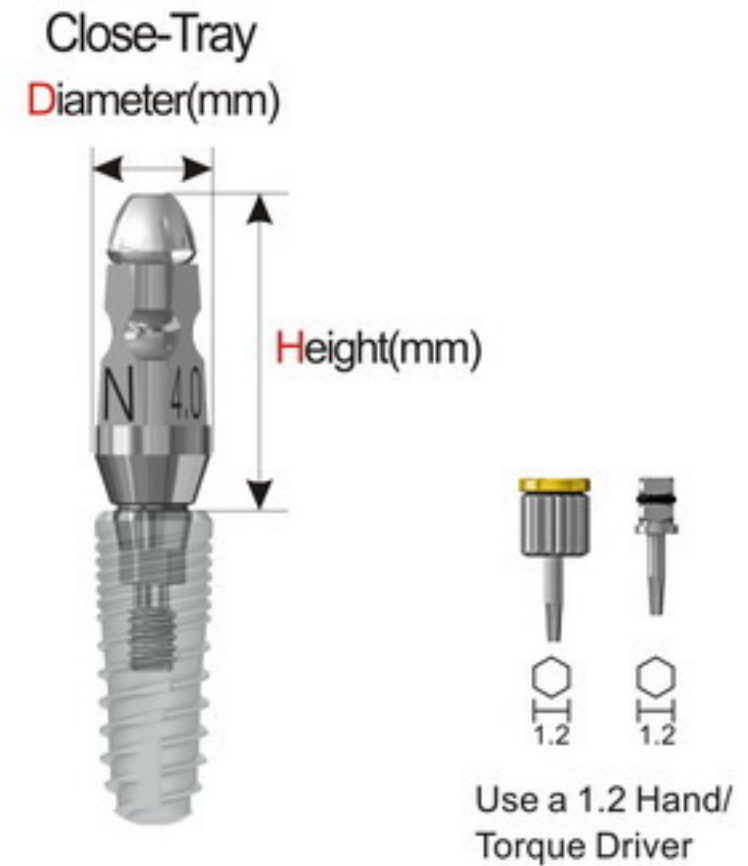

- ◎ Transfer type for ready-made tray
- ◎ Hex design is two-piece design which includes screw
- ◎ Non-Hex design is one-piece

## Narrow

For Ø3.0 / Ø3.5 Fixture

D	H	Type	REF No.
4.0	11	Hex	SBPIN 4011(I)
4.0	11	Non-Hex	SBPIN 4011N(I)
4.0	15	Hex	SBPIN 4015(I)
4.0	15	Non-Hex	SBPIN 4015N(I)

## Narrow

For Ø3.0 / Ø3.5 Fixture

D	H	Type	REF No.
4.0	11	Hex	SBTIN 4011(I)
4.0	11	Non-Hex	SBTIN 4011N(I)
4.0	14	Hex	SBTIN 4014(I)
4.0	14	Non-Hex	SBTIN 4014N(I)

## Standard

For Ø4.0 / Ø4.5 / Ø5.0 Fixture

D	H	Type	REF No.
4.0	11	Hex	SBPIS 4011
4.0	11	Non-Hex	SBPIS 4011N
4.0	15	Hex	SBPIS 4015
4.0	15	Non-Hex	SBPIS 4015N
D	H	Type	REF No.
5.0	11	Hex	SBPIS 5011
5.0	11	Non-Hex	SBPIS 5011N
5.0	15	Hex	SBPIS 5015
5.0	15	Non-Hex	SBPIS 5015N
D	H	Type	REF No.
6.0	11	Hex	SBPIS 6011
6.0	11	Non-Hex	SBPIS 6011N
6.0	15	Hex	SBPIS 6015
6.0	15	Non-Hex	SBPIS 6015N

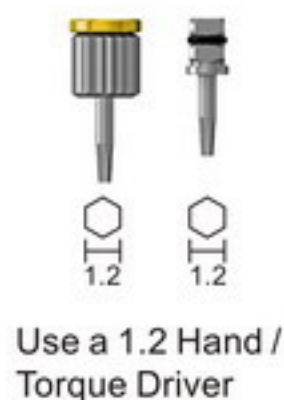

## Standard

For Ø4.0 / Ø4.5 / Ø5.0 Fixture

D	H	Type	REF No.
4.0	11	Hex	SBTIS 4011
4.0	11	Non-Hex	SBTIS 4011N
4.0	14	Hex	SBTIS 4014
4.0	14	Non-Hex	SBTIS 4014N
D	H	Type	REF No.
5.0	11	Hex	SBTIS 5011
5.0	11	Non-Hex	SBTIS 5011N
5.0	14	Hex	SBTIS 5014
5.0	14	Non-Hex	SBTIS 5014N
D	H	Type	REF No.
6.0	11	Hex	SBTIS 6011
6.0	11	Non-Hex	SBTIS 6011N
6.0	14	Hex	SBTIS 6014
6.0	14	Non-Hex	SBTIS 6014N



## Narrow

For Ø3.0 / Ø3.5 Fixture

H	REF No.
11	SBPGPN 150(I)
15	SBPGPN 190(I)

## Standard

For Ø4.0 / Ø4.5 / Ø5.0 Fixture

H	REF No.
11	SBPGPS 150L
15	SBPGPS 190L



## Narrow

For Ø3.0 / Ø3.5 Fixture

H	REF No.
11	SBTGPN11(I)
14	SBTGPN14(I)

## Standard

For Ø4.0 / Ø4.5 / Ø5.0 Fixture

H	REF No.
11	SBTGPS11
14	SBTGPS14



# Temporary Abutment

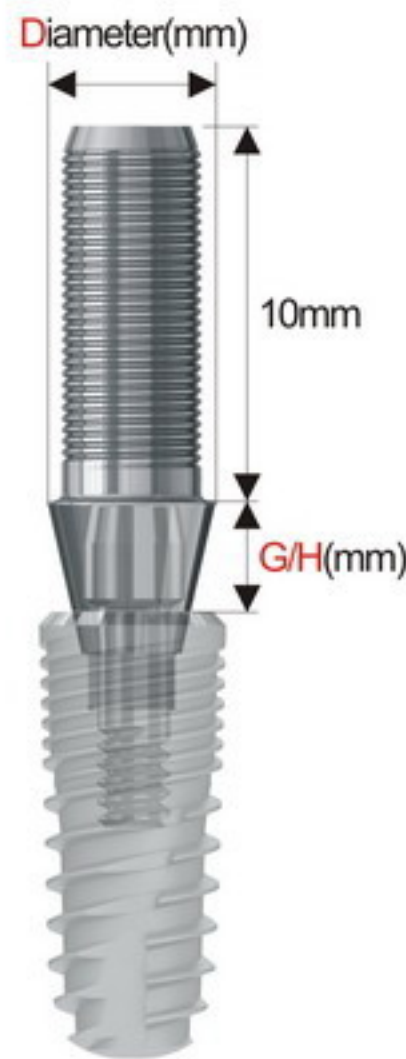

- ⊙ Used for temporary prosthesis
- ⊙ Easy to trim
- ⊙ Hex type : For single dental crown;  
Non-Hex type : For multiple bridge crown.
- ⊙ Use a 1.2 Hand / Torque Driver
- ⊙ Recommended installation: 20Ncm
- ⊙ Package Content: Abutment + Ti Screw
- ⊙ Material: SUS316

## Narrow

For Ø3.0 / Ø3.5 Fixture

D	G/H	Type	REF No.
4.0	1.0	Hex	SBTA 4010(I)
4.0	1.0	Non-Hex	SBTA 4010N(I)
4.0	3.0	Hex	SBTA 4030(I)
4.0	3.0	Non-Hex	SBTA 4030N(I)

## Standard

For Ø4.0/Ø4.5/Ø5.0 Fixture

D	G/H	Type	REF No.
4.5	1.0	Hex	SBTA 4510
4.5	1.0	Non-Hex	SBTA 4510N
4.5	3.0	Hex	SBTA 4530
4.5	3.0	Non-Hex	SBTA 4530N

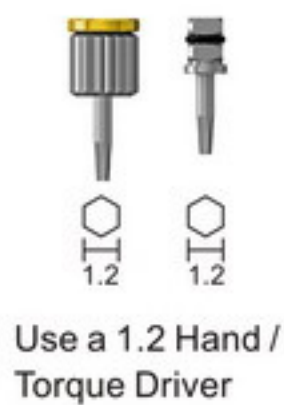

DLC coating improves both mechanical and bio-mechanical properties

# Fixture Lab Analog

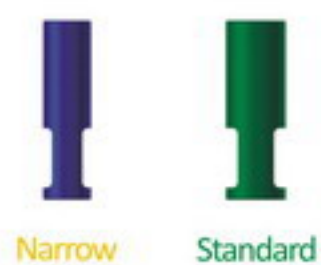

Type	Narrow	Standard
REF No.	SBLA 350(I)	SBLA 400

- ⊙ Place into the cast for model fabrication
- ⊙ **Narrow** : No Scale    **Standard** : One Scale
- ⊙ Material : Ti6Al4V



# O-ring Abutment

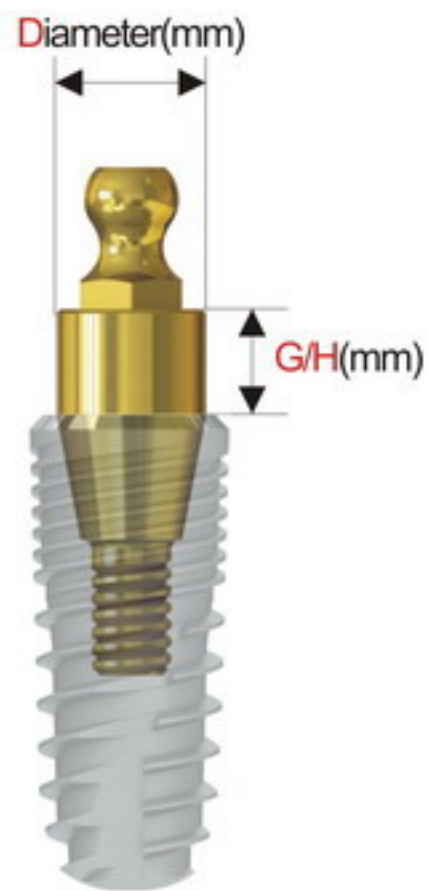

- ⊙ Used for denture restoration
- ⊙ Anodized surface evolves an esthetic outcome
- ⊙ For dental technician: Black
- ⊙ For denture: Yellow(4N), Orange(6N)
- ⊙ Use a O-ring Abutment Driver
- ⊙ Recommended installation: 30Ncm
- ⊙ Package Content: Abutment + Retainer Set
- ⊙ Completely sterilized, with irradiation indication stickers

## Narrow

For  $\varnothing 3.0$  /  $\varnothing 3.5$  Fixture

D	G/H	REF No.
3.5	1.0	SBSAN 3510A(I)
3.5	2.0	SBSAN 3520A(I)
3.5	3.0	SBSAN 3530A(I)
3.5	4.0	SBSAN 3540A(I)
3.5	5.0	SBSAN 3550A(I)
3.5	6.0	SBSAN 3560A(I)



Use a O-ring Torque Driver

## Standard

For  $\varnothing 4.0$  /  $\varnothing 4.5$  /  $\varnothing 5.0$  Fixture

D	G/H	REF No.
3.5	1.0	SBSA 3510A
3.5	2.0	SBSA 3520A
3.5	3.0	SBSA 3530A
3.5	4.0	SBSA 3540A
3.5	5.0	SBSA 3550A
3.5	6.0	SBSA 3560A

# Retainer Set



REF No.
SBRS

- ⊙ Removable components to support O-ring Abutment
- ⊙ Package Content: Retainer + O-ring

# O-ring Lab Analog



REF No.
SBOLA

- ⊙ Place into the cast for model fabrication



# Ti Base

## Narrow

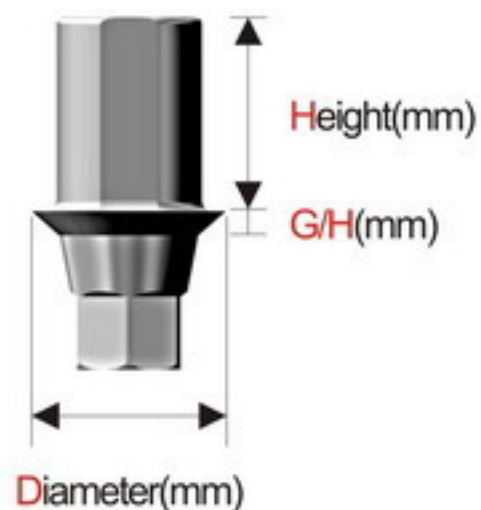

## Standard

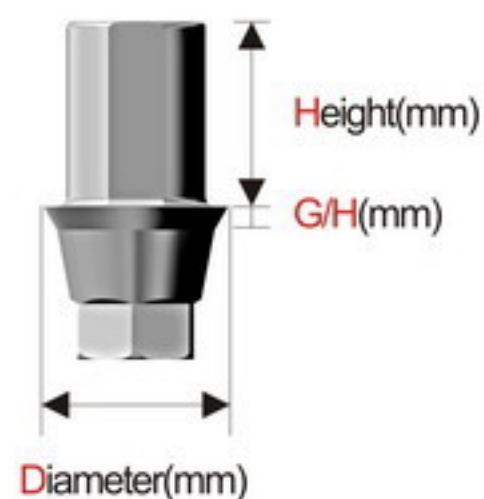

H	D	G/H	Hex	Non-Hex
4	4	0.5	SBTBNIN	SBTBSN
4	4	1.0	SBTBN4010I	SBTBNN4010I
4	4	2.0	SBTBN4020I	SBTBNN4020I

- ⊙Cement type for custom prosthesis
- ⊙Use a 1.2 Hand / Torque Hex Driver
- ⊙Recommended installation: 25Ncm
- ⊙Package content: Ti Base + Ti Screw
- ⊙Non-sterile
- ⊙Material: Ti6Al4V



REF No.
SBABSN(I)

H	D	G/H	Hex	Non-Hex
4	4	0.5	SBTBNI	SBTBS
4	4	1.0	SBTBS4010	SBTBSN4010
4	4	2.0	SBTBS4020	SBTBSN4020

- ⊙Cement type for custom prosthesis
- ⊙Use a 1.2 Hand / Torque Hex Driver
- ⊙Recommended installation: 25Ncm
- ⊙Package content: Ti Base + Ti Screw
- ⊙Non-sterile
- ⊙Material: Ti6Al4V



REF No.
SBABSS



# Mini Surgical Kit



## Lance Drill

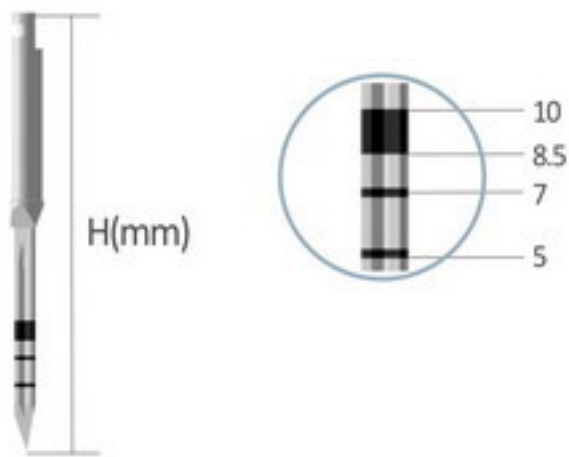

ITEM	H	D	REF No.
Lance Drill	33mm	2mm	ALD001

- ⊙ Used for making implant position
- ⊙ Initial implant site preparation which determines both density and depth of drilling
- ⊙ The sharpness tip of the drill is to minimize the deviation while drilling
- ⊙ The recommended rotation speed is 800-1200rpm

## Sidecut Drill

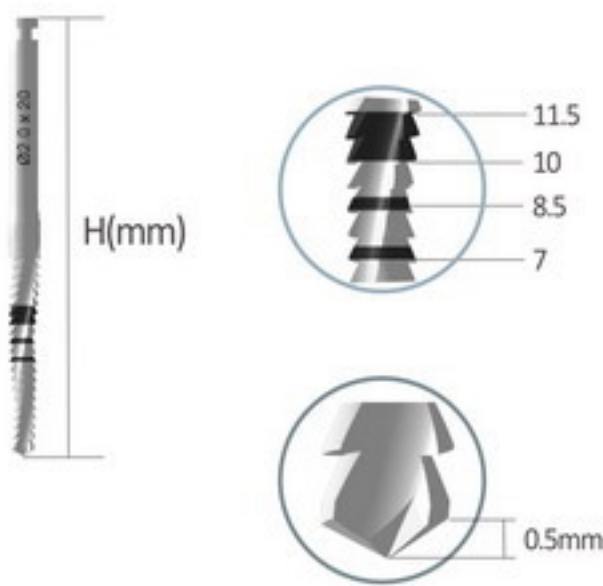

ITEM	H	D	REF No.
Sidecut Drill	35mm	2mm	ASD001

- ⊙ Used for incline trimming to align the drilling position
- ⊙ The recommended rotation speed is 800-1200rpm

## Extension Piece Driver



ITEM	H	REF No.
Extension Piece Driver	27.8mm	AED002S

- ⊙ It can be used if the available vertical space in single tooth gaps in the region of the anterior teeth is insufficient during inserting.
- ⊙ It can also combine with No Mount Drill for implantation



## Twister Drill (Long)

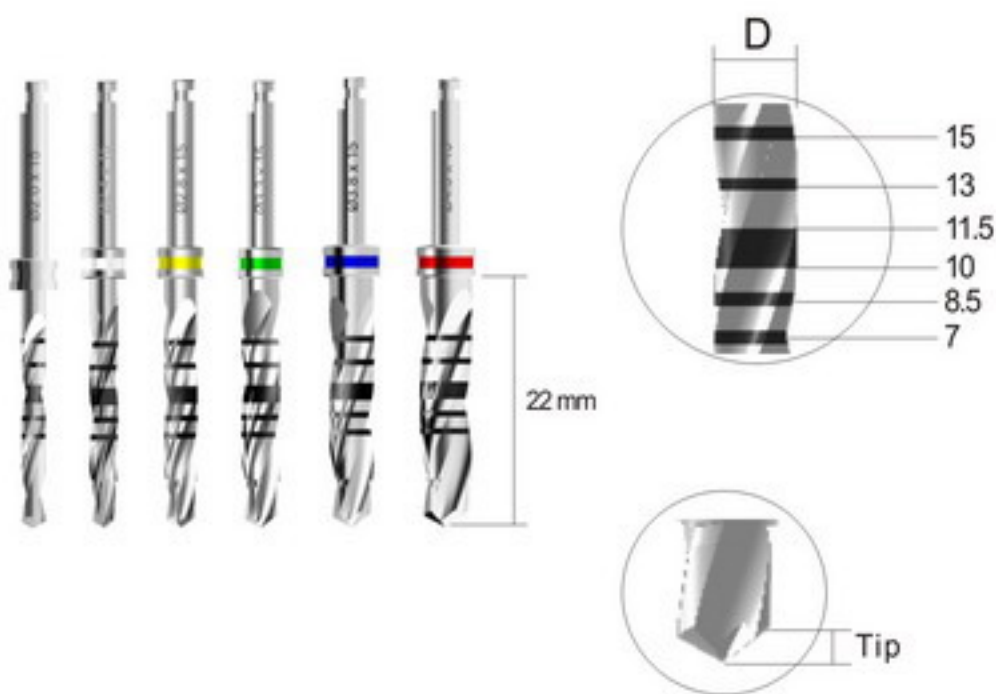

ITEM	H	TIP	REF No.
Ø2.0 Twister Drill	2.0mm	0.58mm	ATWD 2015
Ø2.4 Twister Drill	2.4mm	0.58mm	ATWD 2415
Ø2.8 Twister Drill	2.8mm	0.69mm	ATWD 2815
Ø3.3 Twister Drill	3.3mm	0.81mm	ATWD 3315
Ø3.8 Twister Drill	3.8mm	0.95mm	ATWD 3815
Ø4.3 Twister Drill	4.3mm	1.1mm	ATWD 4315

- ⊙ The specification of Twister Drills are tailored according to the implant sizes adequately
- ⊙ The length of drill is exclusive of tip
- ⊙ The recommended rotation speed is 800-1200rpm

## Taper Cortical Drill

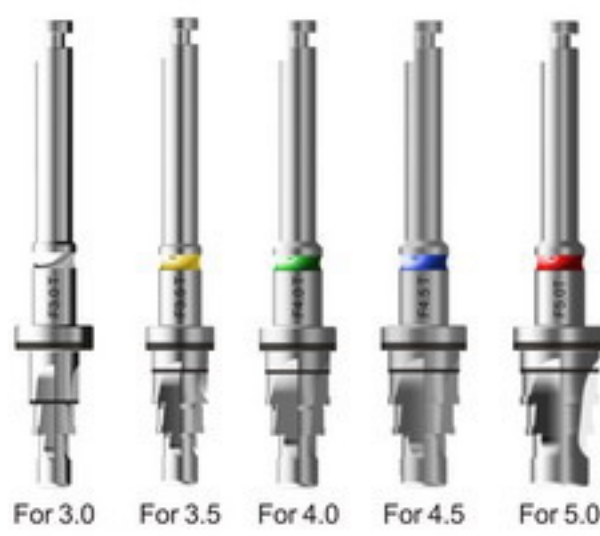

ITEM	REF No.
F3.0 Taper Cortical Drill	ATCD30
F3.5 Taper Cortical Drill	ATCD35
F4.0 Taper Cortical Drill	ATCD40
F4.5 Taper Cortical Drill	ATCD45
F5.0 Taper Cortical Drill	ATCD50

- ⊙ The specification of Straight Cortical Drills are tailored according to the implant sizes adequately
- ⊙ The recommended rotation speed is 800-1200rpm

## Parallel Pins

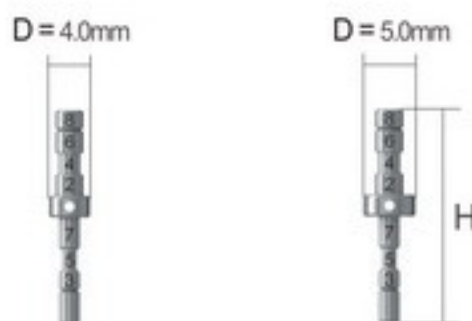

ITEM	H	REF No.
Ø4.0 Parallel Pins	20mm	APP40
Ø5.0 Parallel Pins	20mm	APP50

- ⊙ Used for checking osteotomy direction

## No Mount Piece Driver (Short)



ITEM	H	REF No.
Narrow No Mount Piece Driver S	27mm	ANMPD001S(N)(I)
Standard No Mount Piece Driver S	27mm	ANMPD001S(S)

- ⊙ Used for connecting with the handpiece in order to retrieve the implant
- ⊙ **Narrow** : Ø3.0 / Ø3.5 Fixture
- ⊙ **Standard** : Ø4.0 / Ø4.5 / Ø5.0 Fixture
- ⊙ The maximum insertion torque by using No Mount Piece Driver if it is excessive 25 Ncm must be prohibited



## Fixture Torque Driver (Long)



ITEM	H	REF No.
Narrow Fixture Torque Driver L	24mm	AFD001L(N)
Standard Fixture Torque Driver L	24mm	AFD001L(S)

- ⊙ Use a Simple / Torque Wrench
- ⊙ **Narrow:** Ø3.0 / Ø3.5 Fixture
- ⊙ **Standard:** Ø4.0 / Ø4.5 / Ø5.0 Fixture

## 1.2 Hand Driver



ITEM	H	REF No.
1.2 Hand Driver	26mm	AHD12L

- ⊙ It could be used to remove Cover Screw, Healing Abutment, Fixed Abutment (Ø4.5mm, Ø5.0mm, Ø6.0mm and Ø7.0mm), Ti Screw
- ⊙ Hand Driver could be used manually

## 1.2 Torque Driver



ITEM	H	REF No.
1.2 Torque Driver	22mm	ATD12L

- ⊙ It could be used to remove Cover Screw, Healing Abutment, Fixed Abutment (Ø4.5mm, Ø5.0mm, Ø6.0mm and Ø7.0mm), Ti Screw
- ⊙ Torque Driver could be used with Simple / Torque Wrench

## Simple Wrench



REF No.
CITQW-1185A

- ⊙ "IN" - Inserting clockwise
- ⊙ "OUT" - Withdrawing counter-clockwise
- ⊙ Sterilization by autoclaving is 134°C (273°F)

## Depth Gauge



REF No.
ADG001

- ⊙ A (DEPTH) is used to identify the desired depth has been reached  
The laser markings of A among the lengths from 7-15mm
- ⊙ C (G/H) is used to identify the gingival height  
The laser markings of C are numerical



# PURCHASING ITEMS

## Fixed Piece Driver



ITEM	H	REF No.
Fixed Piece Driver S	22.5mm	AFPD001S

⊙It could be used to place or remove Ø4.0mm Fixed Abutment

## Fixed Torque Driver



ITEM	H	REF No.
Fixed Torque Driver L	24mm	AFTD001L

⊙It could be used to place or remove Ø4.0mm Fixed Abutment  
 ⊙Fixed Torque Driver could be used with Simple/Torque Wrench

## Stopper (Medium)



ITEM	H	REF No.
7.0 Drill Stopper	16.2mm	AST4A07
8.5 Drill Stopper	14.7mm	AST4A08
10 Drill Stopper	13.2mm	AST4A10
11.5 Drill Stopper	11.7mm	AST4A11
13 Drill Stopper	10.2mm	AST4A13
15 Drill Stopper	8.2mm	AST4A15

⊙Used for self-stopping  
 ⊙Available for Ø2.0, Ø2.4, Ø2.8, Ø3.3 drills

## Stopper (Large)



ITEM	H	REF No.
7.0 Drill Stopper	16.2mm	AST5A07
8.5 Drill Stopper	14.7mm	AST5A08
10 Drill Stopper	13.2mm	AST5A10
11.5 Drill Stopper	11.7mm	AST5A11
13 Drill Stopper	10.2mm	AST5A13
15 Drill Stopper	8.2mm	AST5A15

⊙Used for self-stopping  
 ⊙Available for Ø3.8, Ø4.3 drills



# PURCHASING ITEMS

## Twist Drill (Short)

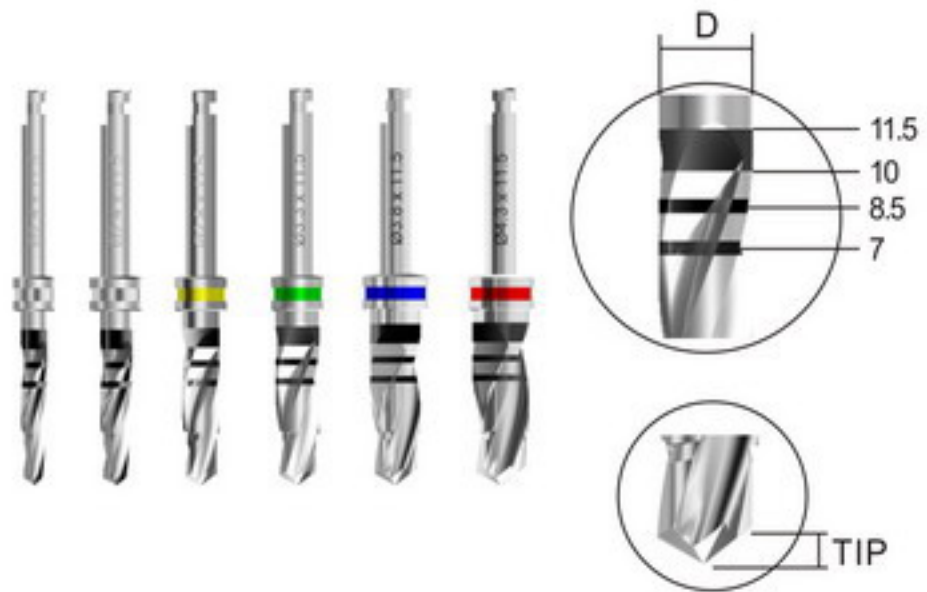

ITEM	D	TIP	REF No.
Ø2.0 Twister Drill	2.0mm	0.6mm	ATWD 2011
Ø2.4 Twister Drill	2.4mm	0.6mm	ATWD 2411
Ø2.8 Twister Drill	2.8mm	0.7mm	ATWD 2811
Ø3.3 Twister Drill	3.3mm	0.8mm	ATWD 3311
Ø3.8 Twister Drill	3.8mm	0.95mm	ATWD 3811
Ø4.3 Twister Drill	4.3mm	1.1mm	ATWD 4311

- ⊙ The specification of Twister Drills are tailored according to the implant sizes adequately
- ⊙ The length of drill is exclusive of tip
- ⊙ The recommended rotation speed is 800-1200rpm



# Taper Surgical Kit



## Lance Drill

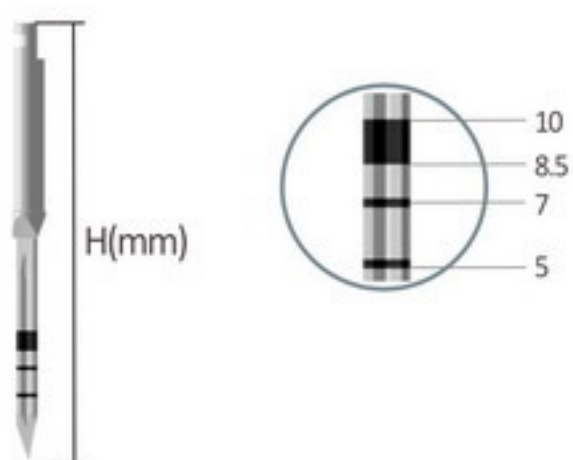

ITEM	H	D	REF No.
Lance Drill	33mm	2mm	ALD001

- ⊙ Used for making implant position
- ⊙ Initial implant site preparation which determines both density and depth of drilling
- ⊙ The sharpness tip of the drill is to minimize the deviation while drilling
- ⊙ The recommended rotation speed is 800-1200rpm

## Sidecut Drill

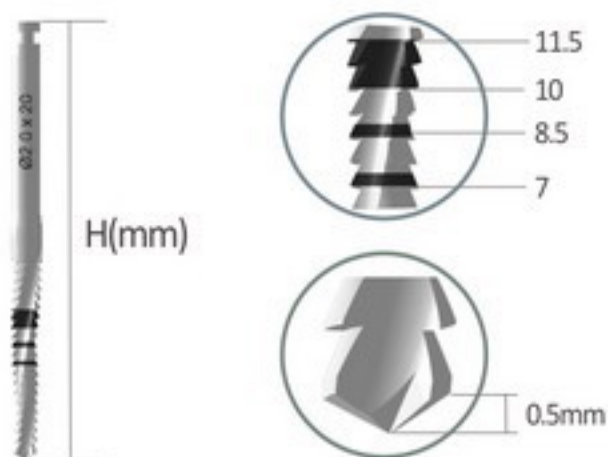

ITEM	H	D	REF No.
Sidecut Drill	35mm	2mm	ASD001

- ⊙ Used for incline trimming to align the drilling position
- ⊙ The recommended rotation speed is 800-1200rpm

## Extension Piece Driver



ITEM	H	REF No.
Extension Piece Driver	27.8mm	AED002S

- ⊙ It can be used if the available vertical space in single tooth gaps in the region of the anterior teeth is insufficient during inserting
- ⊙ It can also combine with No Mount Drill for implantation



## Ø2.0 Twister Drill



ITEM	H	TIP	REF No.
Ø2.0 Twister Drill	8.5mm	0.58mm	ATWD2008
Ø2.0 Twister Drill	10mm	0.58mm	ATWD2010
Ø2.0 Twister Drill	11.5mm	0.58mm	ATWD2011
Ø2.0 Twister Drill	13mm	0.58mm	ATWD2013
Ø2.0 Twister Drill	15mm	0.49mm	ATWD2015

- ⊙ The length of drill is exclusive of tip
- ⊙ The recommended rotation speed is 800-1200 rpm

## F3.0 Taper Drill

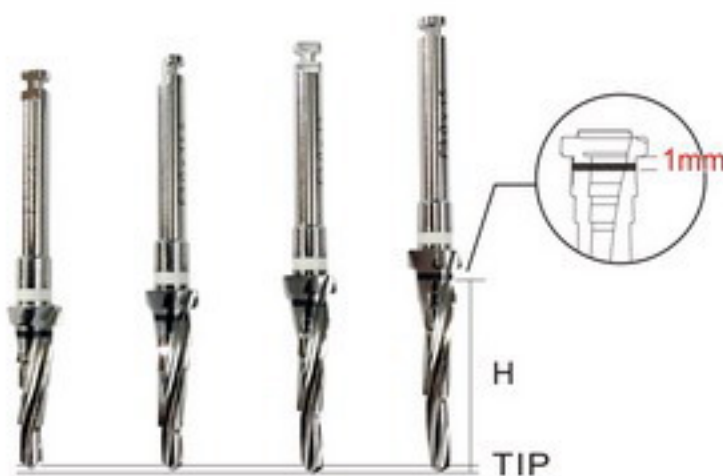

ITEM	H	TIP	REF No.
F3.0 Taper Drill	10mm	0.52mm	ATAD3010
F3.0 Taper Drill	11.5mm	0.52mm	ATAD3011
F3.0 Taper Drill	13mm	0.52mm	ATAD3013
F3.0 Taper Drill	15mm	0.52mm	ATAD3015

- ⊙ Tapered design for Ø3.0mm Fixture
- ⊙ The length of **H** is corresponding with the implant height, and is allowed up to 1mm longer drilling above the black laser line upon the clinical judgement
- ⊙ The recommended rotation speed is 800-1200rpm

## F3.5 Taper Drill

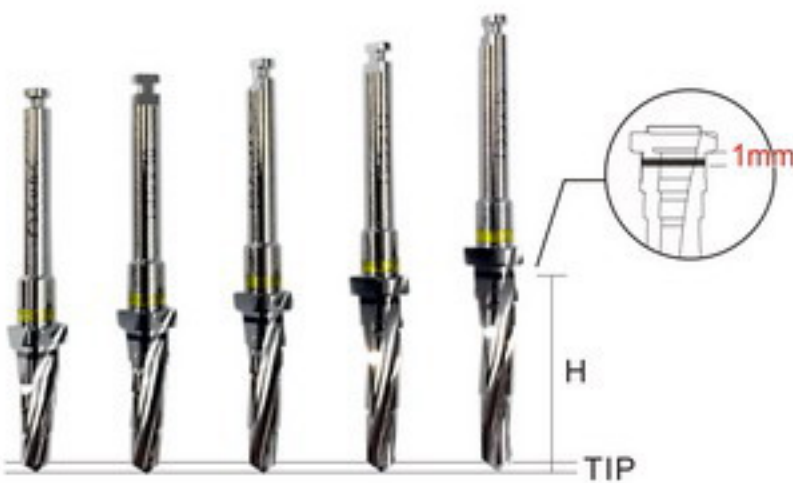

ITEM	H	TIP	REF No.
F3.5 Taper Drill	8.5mm	0.7mm	ATAD3508
F3.5 Taper Drill	10mm	0.72mm	ATAD3510
F3.5 Taper Drill	11.5mm	0.72mm	ATAD3511
F3.5 Taper Drill	13mm	0.74mm	ATAD3513
F3.5 Taper Drill	15mm	0.74mm	ATAD3515

- ⊙ Tapered design for Ø3.5mm Fixture
- ⊙ The length of **H** is corresponding with the implant height, and is allowed up to 1mm longer drilling above the black laser line upon the clinical judgement
- ⊙ The recommended rotation speed is 800-1200rpm

## F4.0 Taper Drill



ITEM	H	TIP	REF No.
F4.0Taper Drill	7mm	0.78mm	ATAD4007
F4.0Taper Drill	8.5mm	0.78mm	ATAD4008
F4.0Taper Drill	10mm	0.79mm	ATAD4010
F4.0Taper Drill	11.5mm	0.79mm	ATAD4011
F4.0Taper Drill	13mm	0.82mm	ATAD4013
F4.0Taper Drill	15mm	0.82mm	ATAD4015

- ⊙ Tapered design for Ø4.0mm Fixture
- ⊙ The length of **H** is corresponding with the implant height, and is allowed up to 1mm longer drilling above the black laser line upon the clinical judgement
- ⊙ The recommended rotation speed is 800-1200rpm



## F4.5 Taper Drill



ITEM	H	TIP	REF No.
F4.5 Taper Drill	7mm	0.89mm	ATAD4507
F4.5 Taper Drill	8.5mm	0.89mm	ATAD4508
F4.5 Taper Drill	10mm	0.95mm	ATAD4510
F4.5 Taper Drill	11.5mm	0.95mm	ATAD4511
F4.5 Taper Drill	13mm	1.01mm	ATAD4513
F4.5 Taper Drill	15mm	1.01mm	ATAD4515

- ⊙ Tapered design for Ø4.5mm Fixture
- ⊙ The length of **H** is corresponding with the implant height, and is allowed up to 1mm longer drilling above the black laser line upon the clinical judgement
- ⊙ The recommended rotation speed is 800-1200rpm

## F5.0 Taper Drill



ITEM	H	TIP	REF No.
F5.0T aper Drill	7mm	1.07mm	ATAD5007
F5.0 Taper Drill	8.5mm	1.07mm	ATAD5008
F5.0 Taper Drill	10mm	1.12mm	ATAD5010
F5.0 Taper Drill	11.5mm	1.12mm	ATAD5011
F5.0Taper Drill	13mm	1.18mm	ATAD5013
F5.0 Taper Drill	15mm	1.19mm	ATAD5015

- ⊙ Tapered design for Ø5.0mm Fixture
- ⊙ The length of **H** is corresponding with the implant height, and is allowed up to 1mm longer drilling above the black laser line upon the clinical judgement
- ⊙ The recommended rotation speed is 800-1200rpm

## Taper Cortical Drill

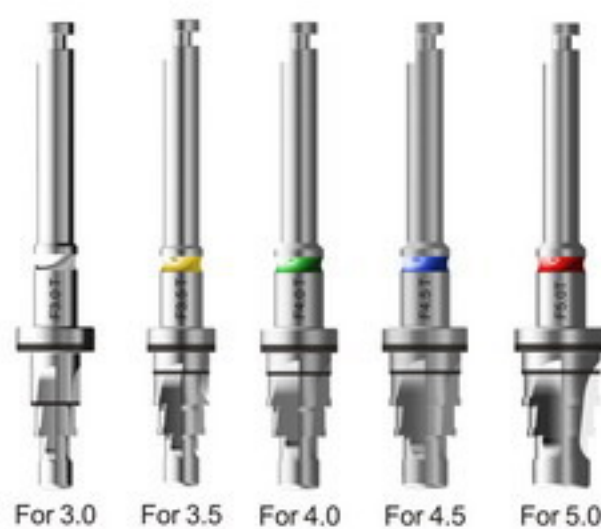

ITEM	REF No.
F3.0 Taper Cortical Drill	ATCD30
F3.5 Taper Cortical Drill	ATCD35
F4.0 Taper Cortical Drill	ATCD40
F4.5 Taper Cortical Drill	ATCD45
F5.0 Taper Cortical Drill	ATCD50

- ⊙ The specification of Taper Cortical Drills are tailored according to the implant sizes adequately
- ⊙ The recommended rotation speed is 800-1200rpm



## Parallel Pins

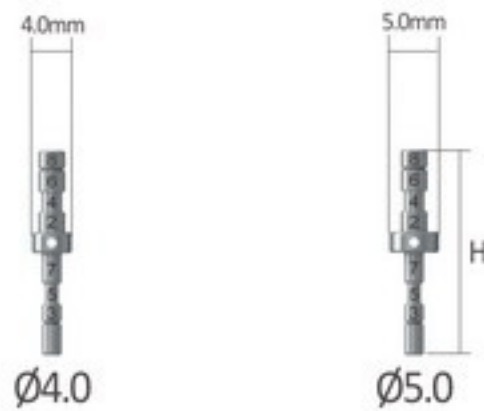

ITEM	H	REF No.
Ø4.0 Parallel Pins	20mm	APP40
Ø5.0 Parallel Pins	20mm	APP50

⊙ Used for checking osteotomy direction

## No Mount Piece Driver



ITEM	H	REF No.
Narrow No Mount Piece Driver S	27mm	ANMPD001S(N)(I)
Narrow No Mount Piece Driver L	32mm	ANMPD001L(N)(I)
Standard No Mount Piece Driver S	27mm	ANMPD001S(S)
Standard No Mount Piece Driver L	32mm	ANMPD001L(S)

⊙ Used for connecting with the handpiece in order to retrieve the implant

⊙ **Narrow:** Ø3.0 / Ø3.5 Fixture

⊙ **Standard:** Ø4.0 / Ø4.5 / Ø5.0 Fixture

⊙ The maximum insertion torque by using No Mount Piece Driver if it is excessive 25 Ncm must be prohibited

## Fixture Torque Driver



ITEM	H	REF No.
Narrow Fixture Torque Driver S	19mm	AFD001S(N)
Narrow Fixture Torque Driver L	24mm	AFD001L(N)
Standard Fixture Torque Driver S	19mm	AFD001S(S)
Standard Fixture Torque Driver L	24mm	AFD001L(S)

⊙ Use a Simple / Torque Wrench

⊙ **Narrow:** Ø3.0 / Ø3.5 Fixture

⊙ **Standard:** Ø4.0 / Ø4.5 / Ø5.0 Fixture

## 1.2 Hand/ Torque Driver

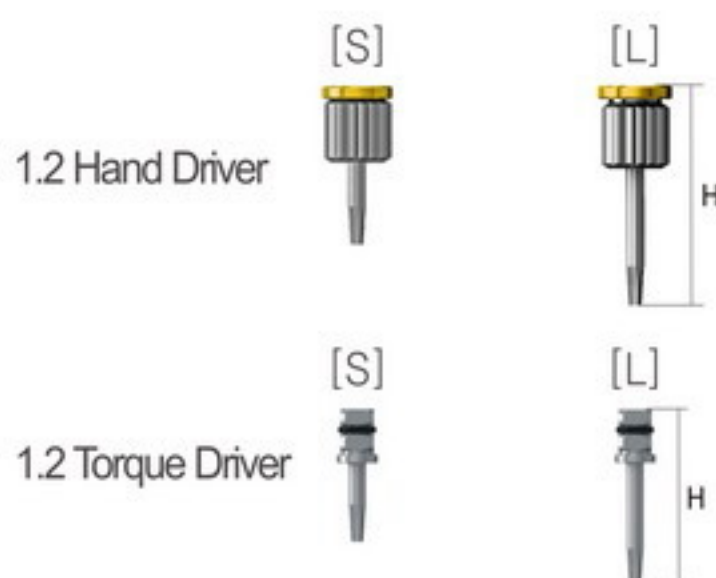

ITEM	H	REF No.
1.2 Hand Driver	21mm	AHD12S
1.2 Hand Driver	26mm	AHD12L
1.2 Torque Driver	16mm	ATD12S
1.2 Torque Driver	22mm	ATD12L

⊙ It could be used to remove Cover Screw, Healing Abutment, Fixed Abutment (Ø4.5mm, Ø5.0mm, Ø6.0mm and Ø7.0mm), Ti Screw

⊙ Hand Driver could be used manually

⊙ Torque Driver could be used with Simple/Torque Wrench



# Torque Wrench



REF No.
ATW001

- ⊙ Readable torque indication
- ⊙ "IN" - Inserting clockwise
- ⊙ "OUT" - Withdrawing counter-clockwise
- ⊙ Sterilization by autoclaving is 137°C (278°F)

# Depth Gauge

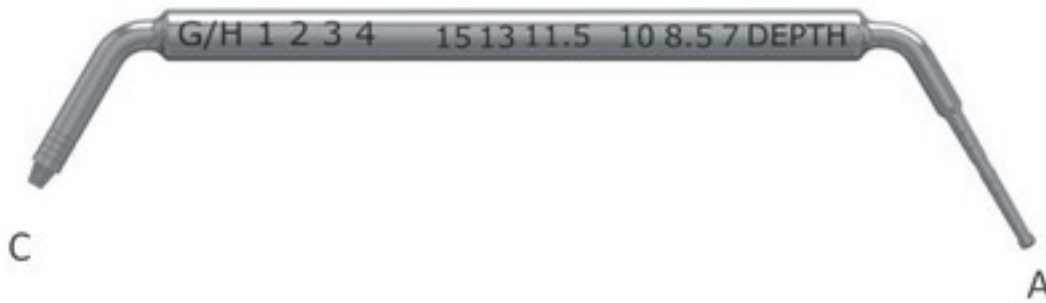

REF No.
ADG001

- ⊙ A (DEPTH) is used to identify the desired depth has been reached  
The laser markings of A among the lengths from 7-15mm
- ⊙ C (G/H) is used to identify the gingival height  
The laser markings of C are numerical

## PURCHASING ITEMS

### Fixed Torque Driver



ITEM	H	REF No.
Fixed Piece Driver S	19mm	AFPD001S
Fixed Torque Driver L	24mm	AFTD001L

- ⊙ It could be used to place or remove Ø4.0mm Fixed Abutment
- ⊙ Torque Fixed Driver could be used with Simple/Torque Wrench

### O-ring Torque Driver













ITEM	H	REF No.
O-ring Torque Driver	20mm	AOTDB001S
	24mm	AOTDB001L
	30mm	AOTDB001XL

- ⊙ Used to place or remove O-ring Abutment
- ⊙ O-ring Driver could be used with Torque Wrench



# Torque Guide

Products	Product description	Installation torque (Ncm)
Cover screw		10 / Ncm
Healing Abutment		10 / Ncm
Fixture Transfer Impression Coping	 Fixture Pick-up Impression Coping 	
Dual Abutment		25 / Ncm
Angled Abutment	 Ti Screw 	
Temporary Abutment		
Fixed Abutment		30 / Ncm
O-ring Abutment		



# Prosthetic Kit



## 1.2 Hand / Torque Drivers

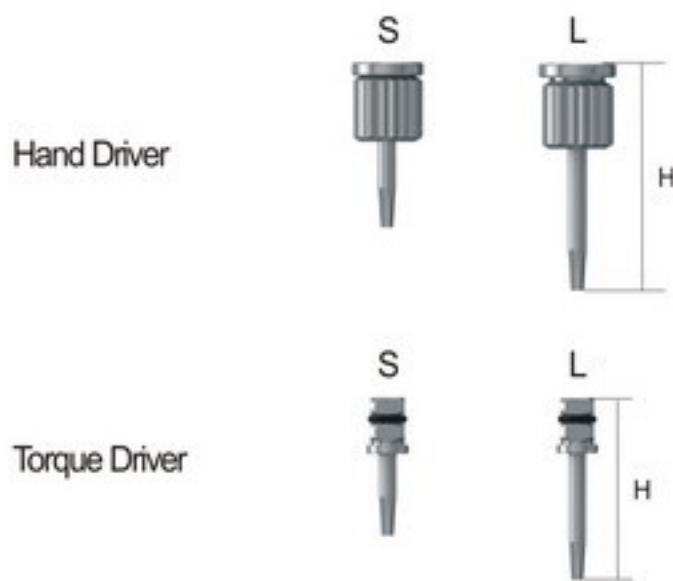

ITEM	H	REF No.
1.2 Hand Driver	21mm	AHD12S
1.2 Hand Driver	26mm	AHD12L
1.2 Torque Driver	16mm	ATD12S
1.2 Torque Driver	22mm	ATD12L

- ⊙ It could be used to remove Cover Screw, Healing Abutment, Fixed Abutment (Ø4.5mm, Ø5.0mm, Ø6.0mm and Ø7.0mm), Ti Screw
- ⊙ Hand Driver could be used manually
- ⊙ Torque Driver could be used with Simple/Torque Wrench

## Fixed Torque Driver

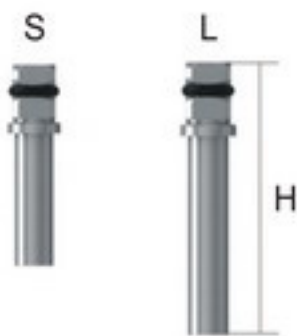

ITEM	H	REF No.
Fixed Torque Driver S	19mm	AFTD001S
Fixed Torque Driver L	24mm	AFTD001L

- ⊙ It could be used to place or remove Ø4.0mm Fixed Abutment
- ⊙ Torque Fixed Driver could be used with Simple/Torque Wrench

## O-ring Driver **PURCHASING ITEMS**



ITEM	H	REF No.
O-ring Torque Driver	20mm	AOTDB001S
	24mm	AOTDB001L
	30mm	AOTDB001XL

- ⊙ Used to place or remove O-ring Abutment
- ⊙ O-ring Driver could be used with Torque Wrench

## 0° Simabutment



ITEM	G/H	REF No.
0° Simabutment	1mm	SBTI 4610(I)
0° Simabutment	2mm	SBTI 4620(I)
0° Simabutment	3mm	SBTI 4630(I)
0° Simabutment	4mm	SBTI 4640(I)

- ⊙ Used for simulating occlusion after the abutment is placed, and determine the gingival height
- ⊙ **Narrow**: Ø3.0mm Fixture
- ⊙ Use a Fixed Driver
- ⊙ Material: Aluminum



# Prosthetic Kit

## 0° Simabutment



Narrow



Standard



ITEM	G/H	REF No.
0° Simabutment	1mm	SBTI 4610
0° Simabutment	2mm	SBTI 4620
0° Simabutment	3mm	SBTI 4630
0° Simabutment	4mm	SBTI 4640

⊙ Used for simulating occlusion after the abutment is placed, and determine the gingival height

⊙ **Narrow:** Ø3.5mm Fixture

⊙ Use a Fixed Driver

⊙ Material: Aluminum

ITEM	G/H	REF No.
0° Simabutment	1mm	SBTI 4611
0° Simabutment	2mm	SBTI 4621
0° Simabutment	3mm	SBTI 4631
0° Simabutment	4mm	SBTI 4641

⊙ Used for simulating occlusion after the abutment is placed, and determine the gingival height

⊙ **Standard:** Ø4.0mm / Ø4.5mm / Ø5.0mm Fixture

⊙ Use a 1.2 Hand/Torque Driver

⊙ Material: Aluminum

## 17° Simabutment



Narrow

Standard



ITEM	G/H	REF No.
17° Simabutment	2mm	SBTI 4320A
17° Simabutment	4mm	SBTI 4340A
17° Simabutment	2mm	SBTI 4520A
17° Simabutment	4mm	SBTI 4540A

⊙ Used for simulating occlusion after the abutment is placed, and determine the gingival height

**Narrow:** Ø3.5mm Fixture

**Standard:** Ø4.0mm / Ø4.5mm / Ø5.0mm Fixture

⊙ Use a 1.2 Hand/ Torque Driver

⊙ Material: Aluminum

## 25° Simabutment



ITEM	G/H	REF No.
25° Simabutment	2mm	SBTI 4320A25
25° Simabutment	4mm	SBTI 4340A25
25° Simabutment	2mm	SBTI 4520A25
25° Simabutment	4mm	SBTI 4540A25

⊙ Used for simulating occlusion after the abutment is placed, and determine the gingival height

**Narrow:** Ø3.5mm Fixture

**Standard:** Ø4.0mm / Ø4.5mm / Ø5.0mm Fixture

⊙ Use a 1.2 Hand/Torque Driver

⊙ Material: Aluminum



# INTERNATIONAL ACTIVITIES



● Germany



2015 IDS

● Dubai



2016 AEEDC

● Singapore



2016 IDEM



● Poland



2016 FDI

● India



2016 Expodent

● USA



2016 CADSSC



● USA



2017 USC International Symposium

● Germany



2017 IDS



# MILESTONE

- 2008** 03 Registered Alliance Global Technology Co. Ltd. In Kaohsiung Science Park
- 07 Signed co-development agreement with Taipei Medical University

---

- 2009** 03 Developed implants, abutments, bone nail and bone plate

---

- 2010** 02 Obtained ISO 13485, ISO9001, CE, TGMP
- 05 Applied for TFDA and U.S. FDA 510K
- 09 Collaboration with Kaohsiung Medical University Animal experiment conducted
- 10 Collaboration with National Cheng-Kung University in SLA-Plus

---

- 2011** 01 Collaboration with Dr. Jian-Tang Zhou ; Acquisition of patents for Tony Cap in Taiwan, Japan and China
- 03 Obtained TFDA -Bone Level Series
- 03 Obtained SLA-Cap Surface Treatment Patent (Dual treated with phosphate and calcium)

---

- 2012** 04 Obtained TFDA -Tissue Level & Mini Implant Series
- 10 Launched the Dental Implantology Training Center in Philippines

---

- 2013** 12 Obtained FDA510K

---

- 2014** 12 Obtained CFDA - Bone-Level Series

---

- 2016** 10 Clinical Experiment in Kaohsiung Medical University

---

- 2017** 02 Established USA Branch in LA
- 06 Established 3D Digital Dental Lab
- 08 Obtained CFDA - Class III
- 12 Obtained TFDA - Ti-Mesh



## Annual Training Course

**2015 /12**

Comprehensive Anker Oral Implant Training Program



**2016 /12**

Anker Implant & Ethic Training Course



**2018 /05**

To be available



# CERTIFICATES



CE0120



ISO 13485



CFDA



CFDA



Taiwan GMP



TFDA



FIXTURE DESIGN PATENT



THREAD DESIGN PATENT



SLA-CaP SURFACE PATENT



2012 National Innovation Award



2013 Academy of Oral Implantology Taiwan Award









2F., No.92, Luke 5th Rd., Luzhu Dist., Kaohsiung City  
82151, Taiwan

TEL : 886-7-6956688 FAX : 886-7-6955329

E-mail : [alliance@anchorfast.com.tw](mailto:alliance@anchorfast.com.tw)



TFDA GMP FDA CFDA

Ver 2.5 EN



201801/500